

The HLE Series Linear Actuators

- For Guiding, Moving and Positioning -



The Dynamic Linear Actuator

for guiding, moving and positioning, even over long travels, we offer:

- High speeds up to 5 m/s
- Transmissible drive torque max. 108 Nm
- Long strokes up to 20 m
- High load bearing capacity horizontal up to 1000 kg / vertical up to 300 kg
- Repeatability up to ± 0.05 mm
- High mechanical efficiency of 95 %
- Two profile sizes: LEB100 and LEB150 - can be combined in a modular system
- Simple, fast mounting and commissioning

Typical Areas of Application

within the scope of innovative and cost-effective machine and system design:

- Handling technology e.g. palletizing, material feed and removal
- Textile machine construction e.g. cross-, length cutting and stacking, quilting, seaming
- Process engineering e.g. varnishing, coating, gluing
- Stock technology e.g. commissioning, stock-keeping
- Construction technology E.g. encasing, inserting steel reinforcements into concrete
- Clean room technology e.g. wafer transport, wafer coating
- Machine tool manufacturing e.g. charging of the work pieces, changing the tools
- Testing technology e.g. guiding of ultrasonic sensors

The Sophisticated Technology

proven in many applications offers the following advantages for your tasks:

- Frictionless motion ensures:
 - low abrasion (suitable for clean room up to class 10)
 - low wear
 - Maintenance-free operation
 - low-noise
 - high efficiency and
 - high service life
- High dynamics due to low-mass, backlash-free carriage
- Simplified inspection with long inspection intervals.
- Longitudinal grooves on all surfaces integrated on all sides of the profile for mounting attachments or for us as a cable duct
- Exchange of toothed belt without dismounting of the load attachment plate
- Flexible installation options provided by longitudinal grooves in the load attachment plate

The HLE - A Sophisticated Technology

The All-Purpose Actuator

The HLE linear actuator offers an appropriate solution for all motion tasks. It is ideal for use as a single axis, or as a component in a multiple axis system.

It has been developed for rapid linear movements over long stroke distances. The HLE provides a simple machine and system element and can be used without the need for any specialized knowledge. Installation and starting up only requires a small amount of effort from the user. The HLE is supplied in many different configurations with numerous options and many accessories.

Our Experience

You can trust in our experience and skill, as over 25000 actuators are already in use throughout the world - be it in automatic textile equipment, handling systems, packaging machines, automatic painting and binding equipment...etc.

The HLE can be found in a wide range of applications: in clean rooms, in the food industry, production plants in the chemical industry or in the manufacture of prefabricated concrete components.

We cooperate with a wide range of different industrial sectors including the automotive industry, machine tool manufacturers, microelectronics manufacturers - and hopefully soon with you...

Examples/Applications

- **Mercedes Benz**, Sindelfingen: Handling cockpit parts in the S-class
- **IBM**, Böblingen: Wafer transport in chip production
- **Bosch-Siemens Hausgeräte GmbH**, Traunreut: Handling cookers
- **SEL**, Stuttgart: Picking electronic components
- **Bayer**, Bitterfeld: Palletizing folding cartons (flat pack boxes) for pharmaceuticals
- **LT Engineering**, Switzerland: Shelf-picking unit for small parts stores
- **Braas**, Steinfeld: Handling roof tiles
- **Philips**, Netherlands: Handling screen masks
- **Weckenmann**, Dormettingen: Setting shell profiles in the concrete industry.

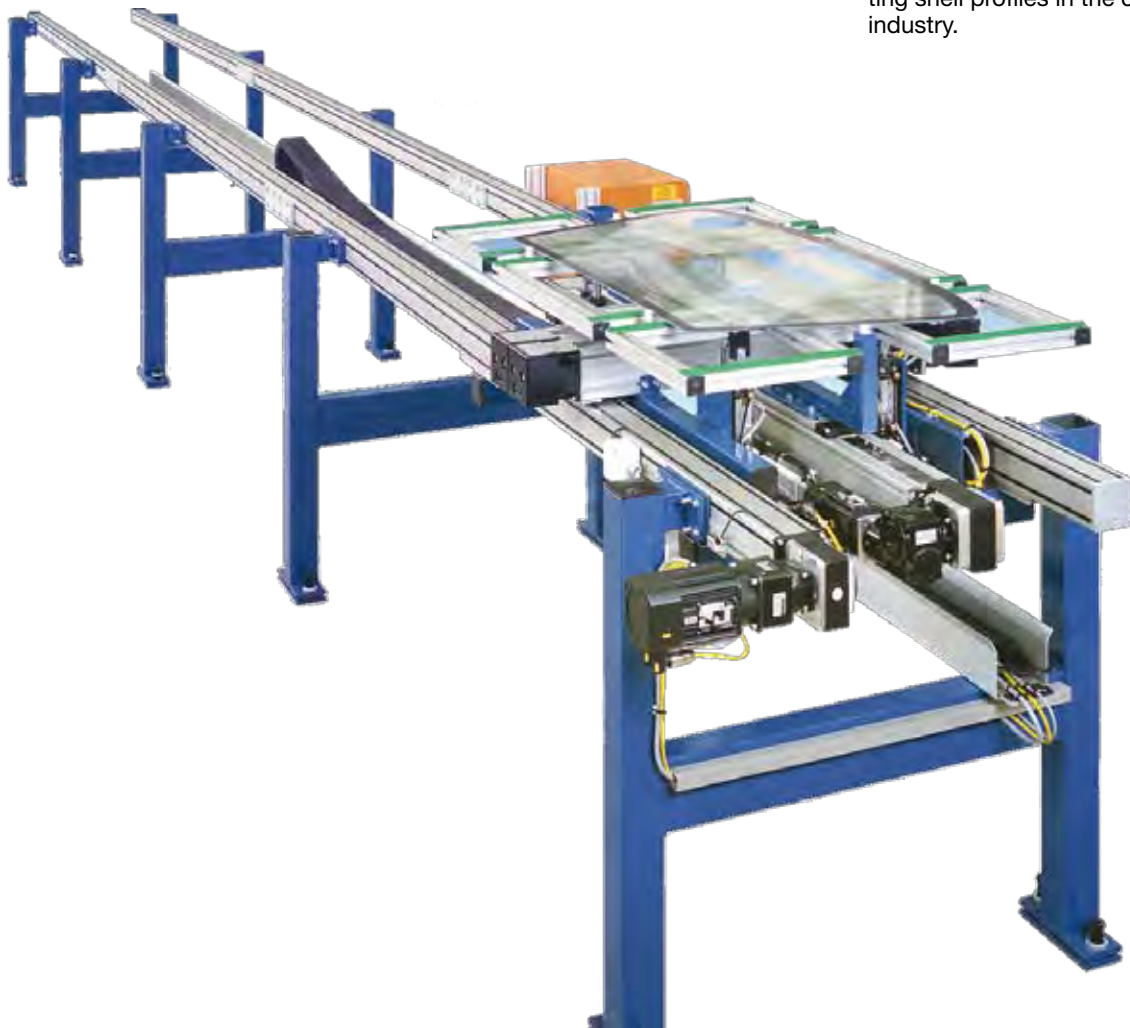

HLE Drive Principle

The HLE consists of an extruded, self-supporting aluminum profile and a carriage, which is fitted backlash-free into the profile with the aid of rollers and is moved via a timing belt.

The steel tension cords integrated into the belt provide the necessary stiffness and prevent an extension of the belt. Special toothed pulleys ensure backlash-free operation - and therefore an excellent repeatability even with long strokes at high speeds.

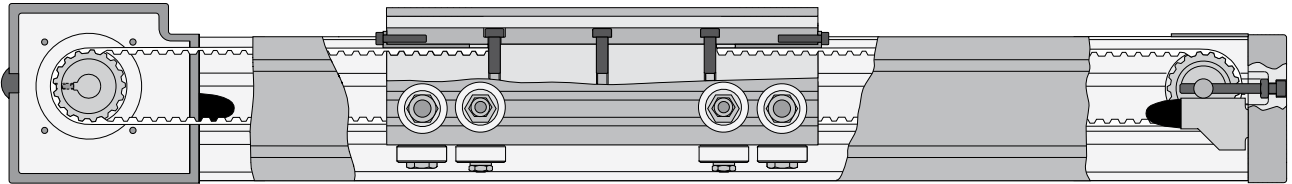

Design and Function of the Optional Steel Strip Cover

The optional steel strip cover is perfectly integrated into the HLE design and protects toothed belt, rollers and the running surfaces of the profile reliably from contamination (protection class IP30).

The t-grooves of the load attachment plate and of the HLE basic profile are suitable for t-nuts in accordance with DIN508 and t-bolts in accordance with DIN787 (T-nuts and bolts: refer to page 32)

Protective covers prevent dust from entering the HLE profile.

A felt insert held down by a spring prevents contamination reliably

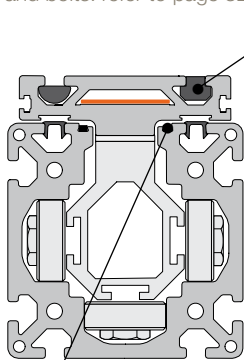

Magnet strips integrated into the profile ensure that the steel strip seals the profile tightly

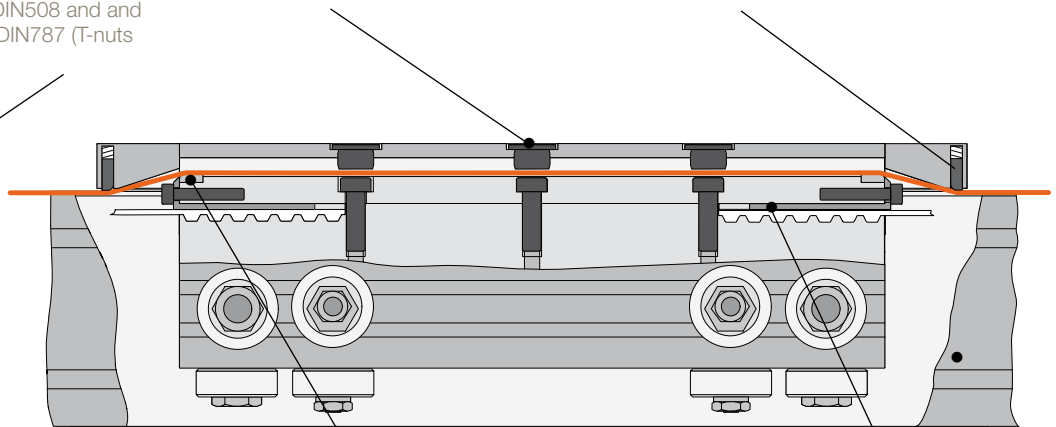

Plastic inlays serve as bearing surface for the steel strip

The toothed belt is fixed to the carriage with the aid of a clamping piece. Loosening the fixing screw permits to exchange the toothed belt without dismantling the load attachment plate.

Construction of the HLE

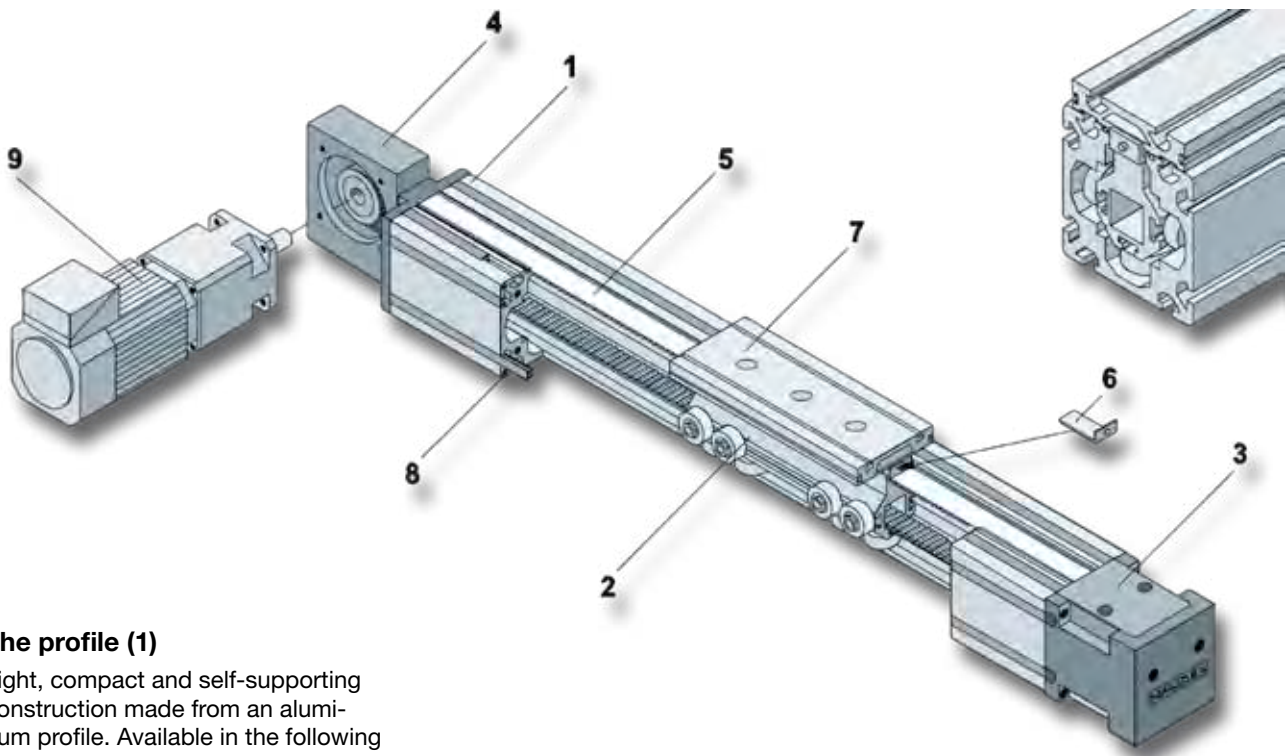

The profile (1)

Light, compact and self-supporting construction made from an aluminum profile. Available in the following cross-sections:

- 100x100 mm (LEB100)
- 150x150 mm (LEB150)

All profiles feature eight lengthwise clamping grooves for the attachment of additional mechanical components and for the connection of several HLE actuators. These grooves can also be used to attach initiators and mechanical switches.

These grooves are also suitable as cable ducts if equipped with the available cover profile (8).

The carriage (2)

Light, rigid carriage with plastic rollers. Overall, this results in high mechanical efficiency and virtually wear-free operation. The rolling-contact plastic rollers with lifetime lubrication are aligned backlash-free in all directions via eccentric. The carriage is available in two sizes as a standard carriage with twelve rollers or as an extended carriage with twenty-four rollers. Customer-specific special carriages are available on request.

The tensioning station (3)

An easily maintained and assembly-friendly tensioning station for setting the tension required for the toothed belt and its orientation (parallelism of pulleys).

The drive station (4)

Robust cast casing with standard flange. Many gear reducers can be directly flange-mounted (for bore pattern, refer to dimensions). Available with drive shaft on the right, on the left or on both sides on request.

The toothed belt (5)

The practically backlash-free toothed belt reinforced by steel tension cords guarantees high travel speeds and repeatabilities.

Toothed belt clamping (6)

The toothed belt fixing bracket ensures a safe connection of toothed belt and carriage. The clamping system allows the toothed belt to be changed without removing the load attachment plate. This means that it is in most cases not necessary to remove the mounted components.

The load attachment plate (7)

- Many possibilities to mount parts by integrated longitudinal grooves at the upper side of the plate. In connection with the clamping profiles (page 32), this allows an easy integration into multi-axis systems.

- Simple and variable mounting of a tripping plate due to lateral longitudinal grooves on the load attachment plate.
- The unit height and the fixing points remain unchanged even if a steel strip cover is mounted in retrospective.

Special versions are available on request.

The drive unit (optional) (9)

Parker servo motor and an appropriate planetary gearbox provide an optimum drive for dynamic and accurate applications.

In connection with the compact Compax3 servo drive, you can dispose of a complete, plug-in automation system for single and multi axis linear- and path control.

The V2A version (Material design V)

Minimized particle emissions and high levels of resistance to water and various cleaning agents make the V2A version of the HLE the number one choice for use in clean rooms or in the food industry.

The steel components are made of V2A material and the rollers and toothed pulleys are equipped with corrosion-free bearings.

Technical Data

HLE - size		100		150	
	Unit	Standard	Steel strip cover	Standard	Steel strip cover
Weights and mass moments of inertia					
Weight of base unit without stroke					
HLE with standard carriage S	[kg]	11.5	12.7	28.6	31.2
HLE with extended carriage E	[kg]	14.6	15.8	35.9	38.5
Mass of standard carriage S including load attachment plate	[kg]	2.5	2.8	6.7	7.3
Mass of extended carriage E including load attachment plate	[kg]	4.1	4.4	10.9	11.5
Additional weight per meter of stroke	[kg/m]	9.9	10.0	21.0	21.1
Mass moment of inertia relative to the drive shaft					
Standard carriage S	[kgcm ²]	22.3	24.6	114.0	123.3
Extended carriage E	[kgcm ²]	34.1	36.4	174.4	183.6
Travel lengths and speeds					
Maximum travel speed ¹	[m/s]	5.0		5.0	
Maximum acceleration ¹	[m/s ²]	10.0		10.0	
Maximum travel, standard carriage S/T ² with one profile bar	[mm]	6300	6210	8230	8140
Maximum travel, extended carriage E/F ² with one profile bar	[mm]	6150	6060	8080	7990
Overall dimensions & physical data					
Cross-section	[mm x mm]	100 x 100		150 x 150	
Moment of inertia I _x	[cm ⁴]	383		1940	
Moment of inertia I _y	[cm ⁴]	431		2147	
Moment of inertia I _t	[cm ⁴]	117		391	
E-modulus (aluminum)	[N/mm ²]	0.72 x 10 ⁵			
Toothed pulley data, Torques, Forces und Efficiency					
Travel distance per revolution	[mm/rev]	170		240	
Diameter of pulley	[mm]	54.113		76.394	
Toothed belt width / pitch	[mm]	25 / 10		32 / 10	
Weight of toothed belt	[kg/m]	0.166		0.213	
Nominal drive torque	[Nm]	15.7		51.4	
Maximum drive torque ³	[Nm]	40		108	
Nominal belt traction force (payload)	[N]	580		1350	
max. belt traction force ³ (payload)	[N]	1478		2827	
Repeatability ⁴	[mm]				
- up to 3 m		±0.05		±0.05	
- as from 3 m		±0.1		±0.1	
Efficiency	[%]	95			

Please contact Parker if your application has the following requirements:

- ¹ Travel speeds over 5 m/s und Accelerations over 10 m/s².
- ² Longitudinal flanges for longer strokes are possible. The following constraints are to be expected with: max. permissible load, drive torque, speed, acceleration, repeatability (see page 34)
- ³ Increased toothed belt tension is required.
- ⁴ At a constant ambient and operating temperature of the actuator. Determined in accordance with ISO 230-2.

➔ Safety factor taken into consideration S=1. Data applies to a temperature range between -10 °C and + 40 °C

HLE Toothed Belt Load Bearing Capacity

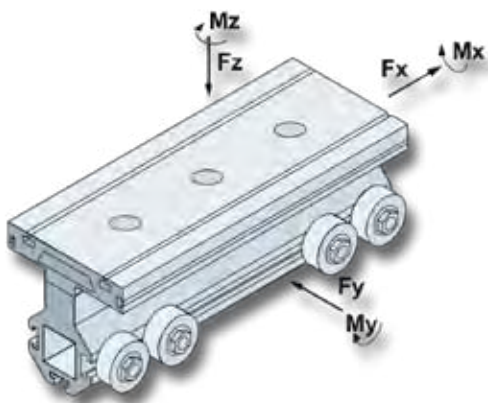

Forces and torques transferred by the carriage are speed-dependant. The graphs shown in the diagrams only apply to standard carriages (S/T).

In the case of extended carriages (E or F), all values with the exception of F_x (toothed belt load bearing capacity) can be doubled if the load is introduced in pairs or is distributed evenly over the entire length of the carriage. The curves show the maximum load-bearing capacity of a carriage in one direction of force or torque.

If several loads are applied in different directions, the values specified in the curves **must be derated**, i.e. the load or speed should be reduced. For precise dimensioning, our software "DimAxes" is available (Refer to "Additional Accessories / Software", page 44).

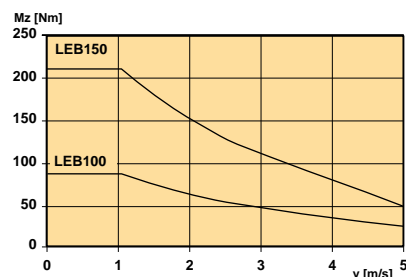
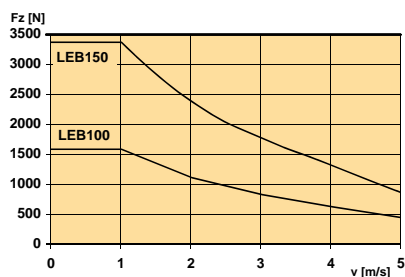
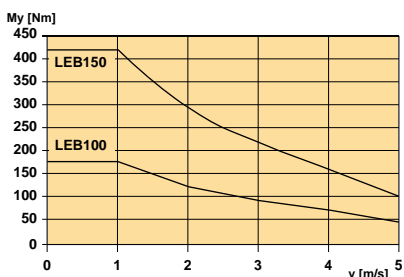
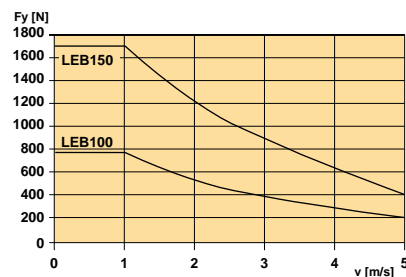
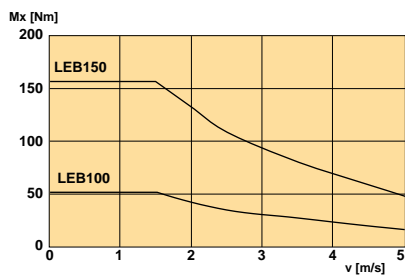
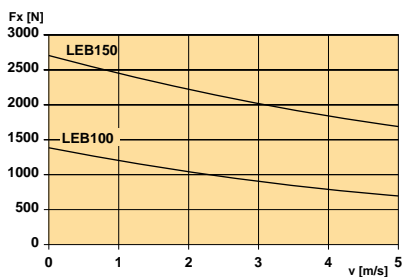

Dimensional Drawings

Dimensions in [mm]
Schematic representation

HLE100 - single axis (LEB100)

Gearbox flange R (for PE5 gearboxes)

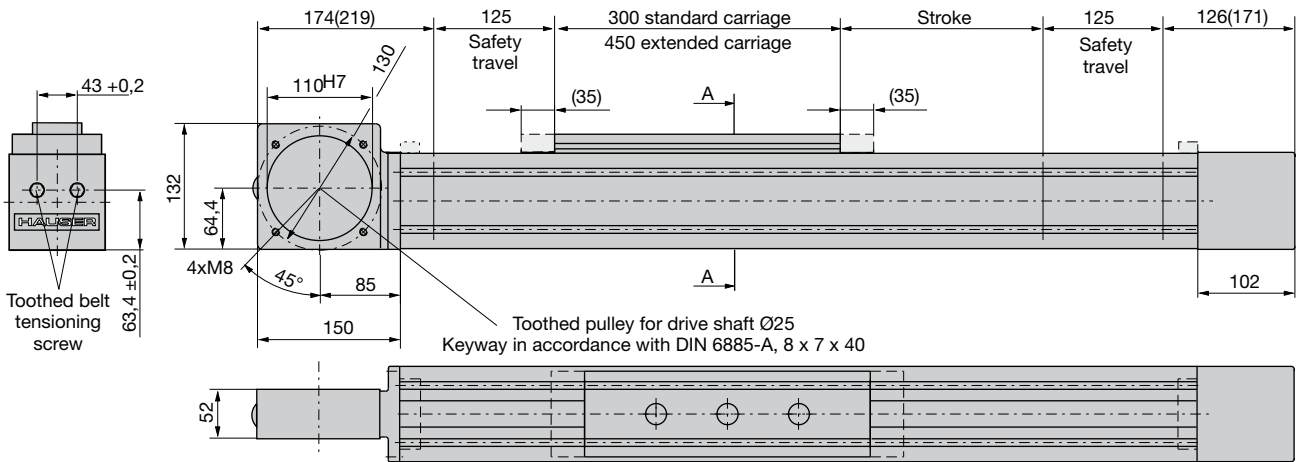

Section A-A enlarged

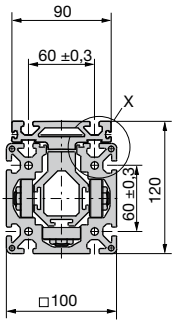

Detail X

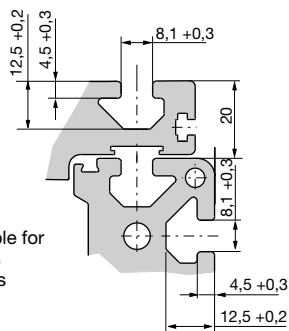

Grooves suitable for
DIN 508 T-nuts
DIN 787 T-bolts

Gearbox flange A (for P3 gearboxes)

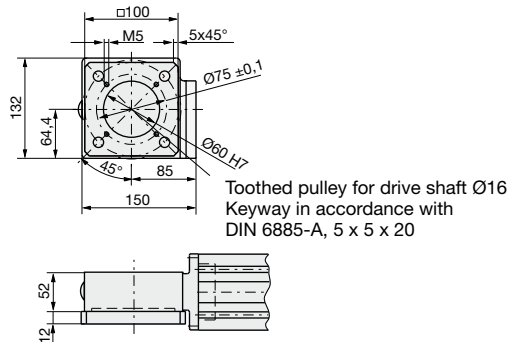

Gearbox flange B (for P4 gearboxes)

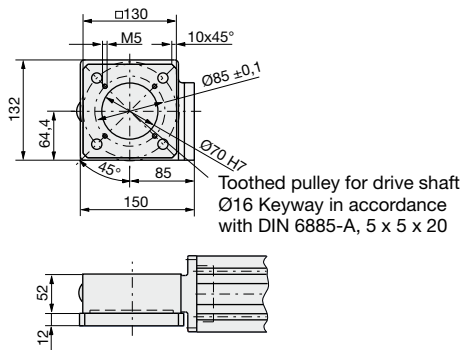

Gearbox flange Q (for PE4 gearboxes)

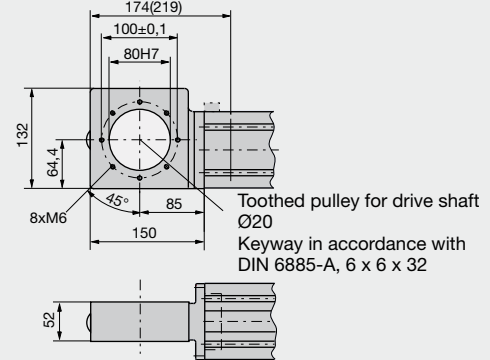

Gearbox flange K (for PS60 gearboxes)

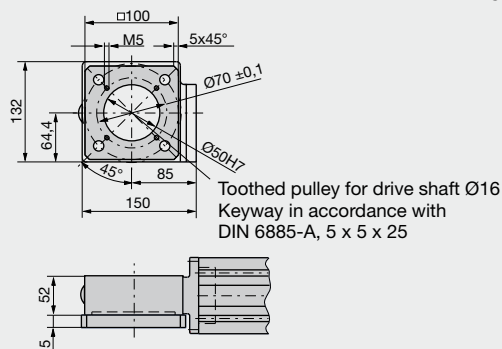

Gearbox flange M (for PS90 gearboxes)

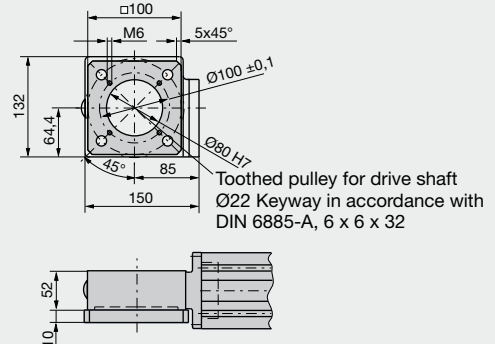

Dimensions in () are valid in connection with steel strip cover Components adumbrated in dashed lines: Steel strip cover option Housing excess at drive and tensoring station approx. 1 mm

HLE100 - drive housing with drive shafts (LEB100)

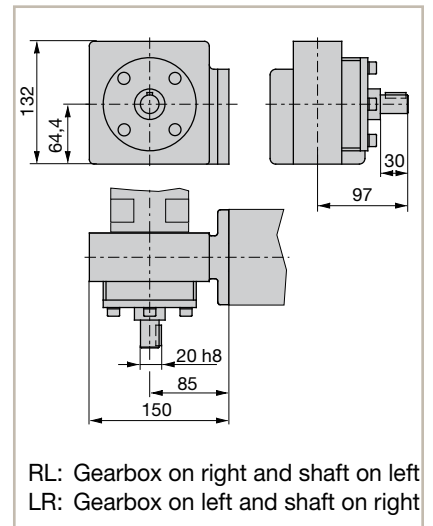
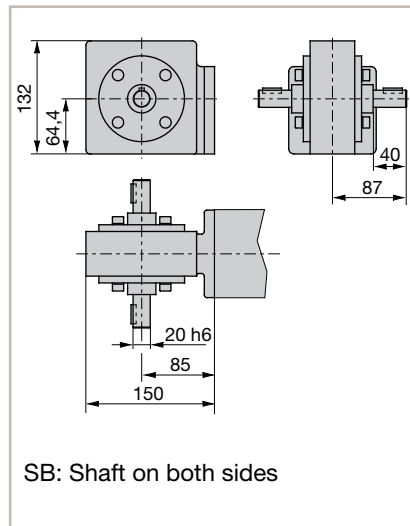
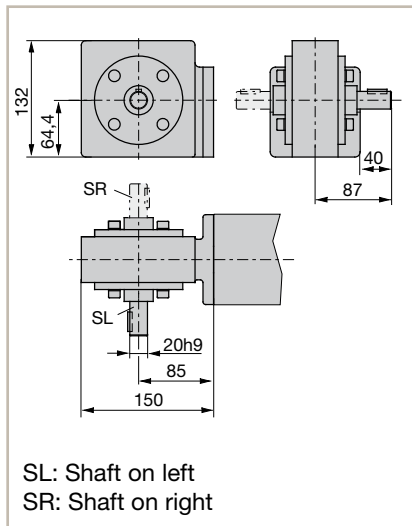

HLE100 - double axis with gearbox flange Q and R (LEB100)

(for flange dimensions please refer to the HLE100 dimensional drawing on page 18)

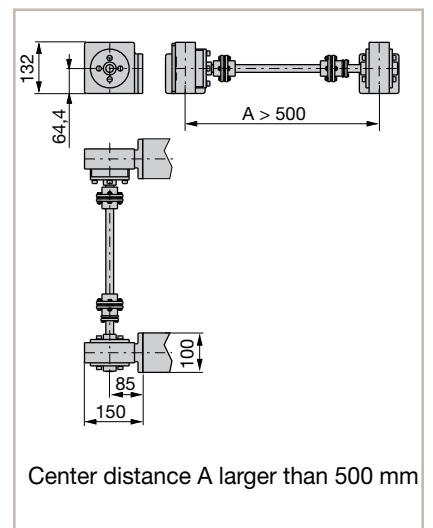
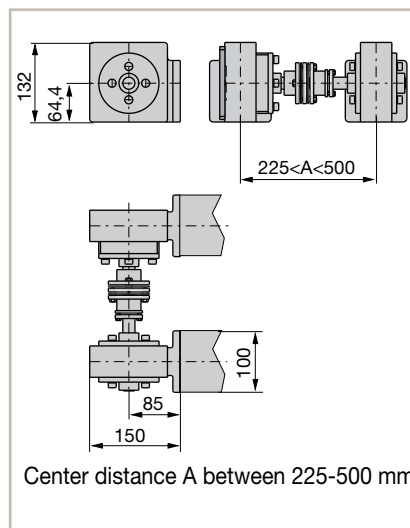
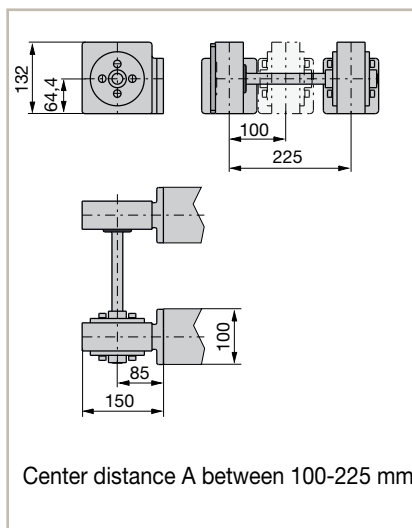

HLE100 - double axis with gearbox flange B (LEB100)

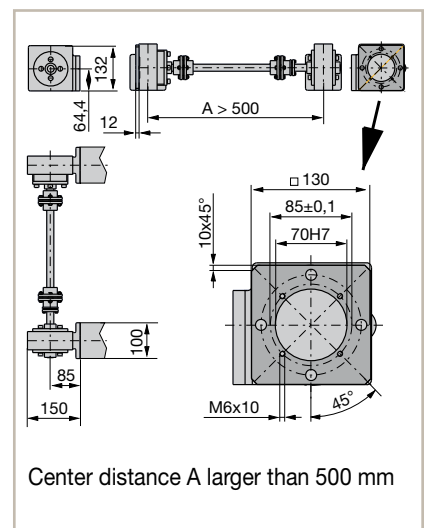
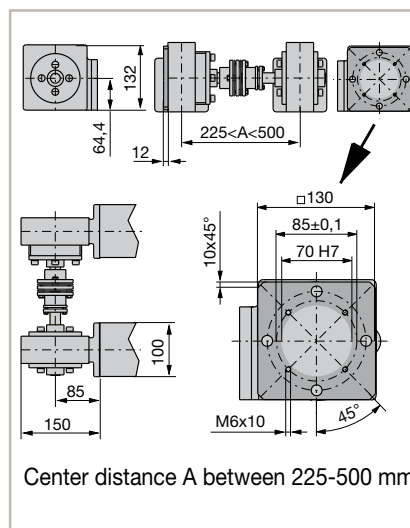
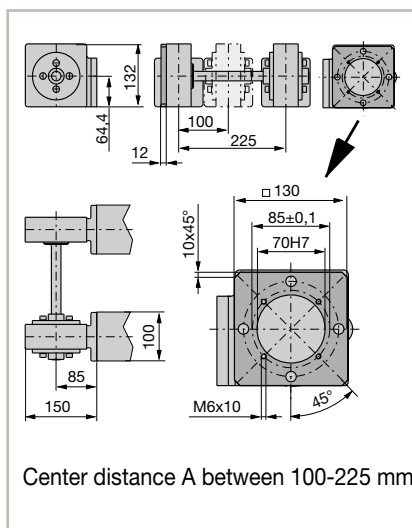

HLE150 - single axis (LEB150)

Gearbox flange R (for PE5 gearboxes)

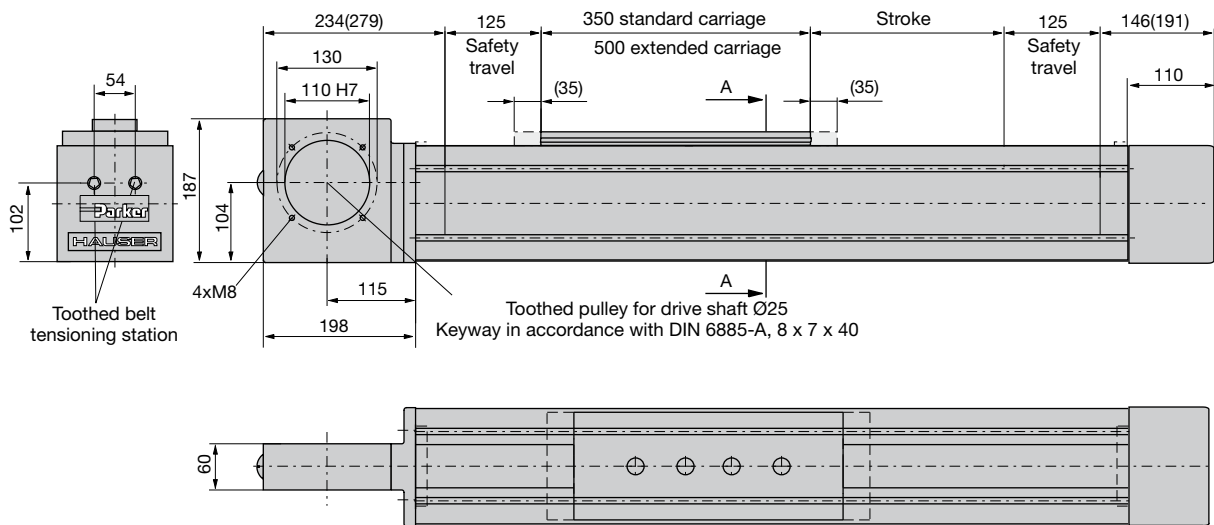

Section A-A enlarged

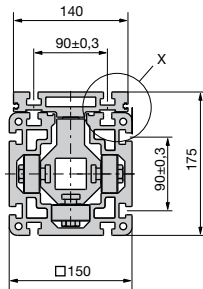

Detail X

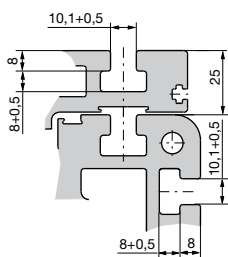

Grooves suitable for
DIN 508 T-nuts
DIN 787 T-bolts

Gearbox flange B (for P4 gearboxes)

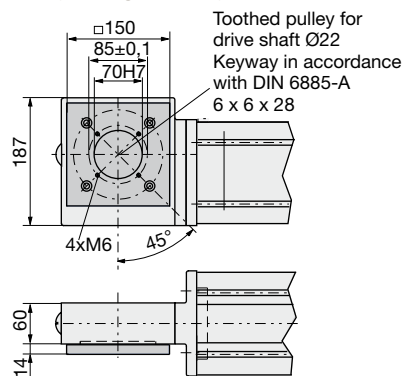

Gearbox flange C (for P5 gearboxes)

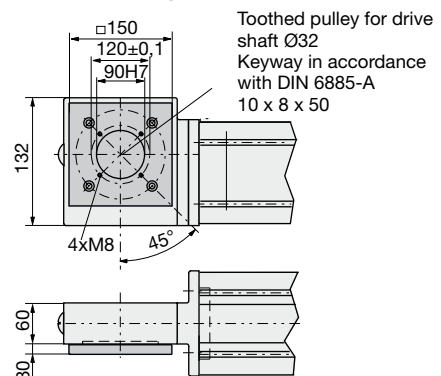

Gearbox flange M (for PS90 gearboxes)

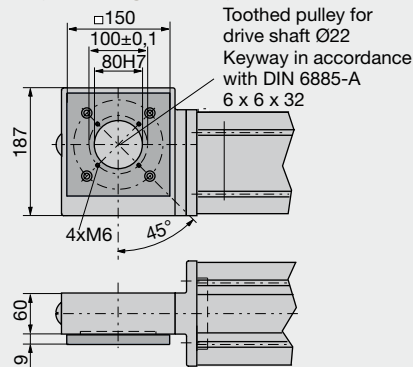

Gearbox flange P (for PS115 gearboxes)

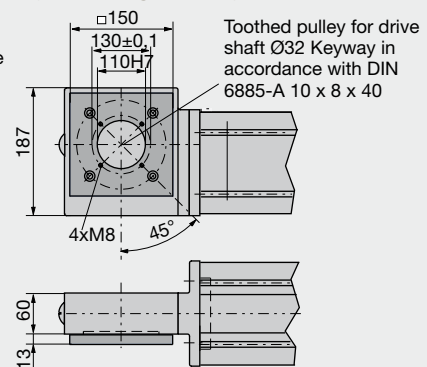

Dimensions in () are valid in connection with steel strip cover Components adumbrated in dashed lines: Steel strip cover option Housing excess at drive and tensioning station approx. 1 mm

HLE150 - drive housing with drive shafts (LEB150)

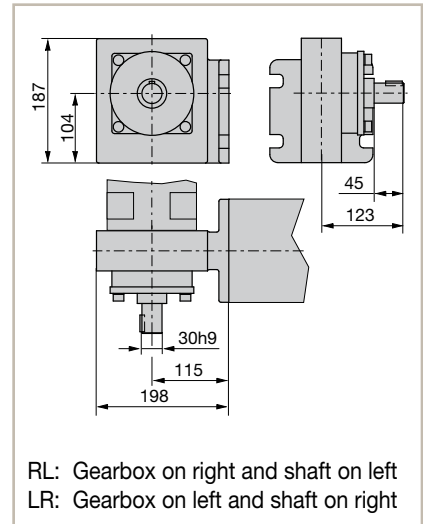
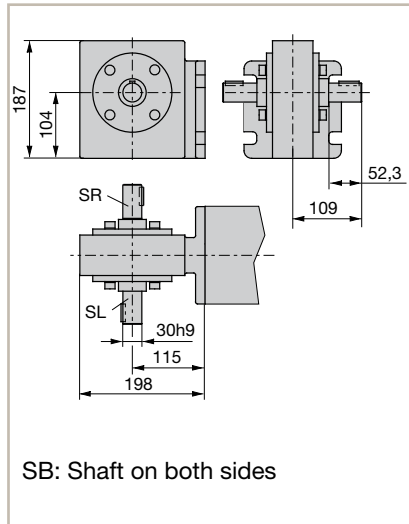
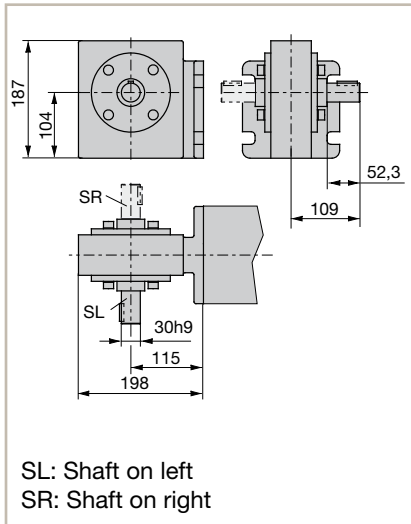

HLE150 -double axis with gearbox flange R (LEB150)

(for flange dimensions please refer to the HLE150 dimensional drawing on page 20)

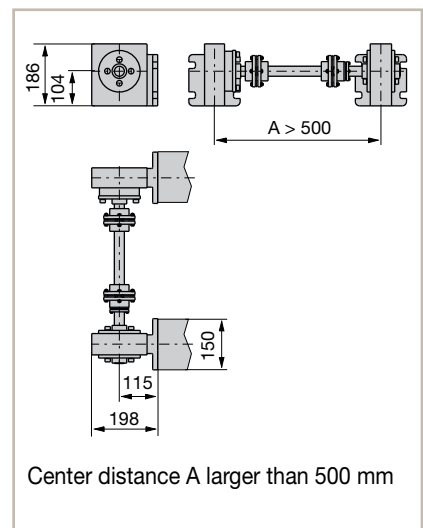
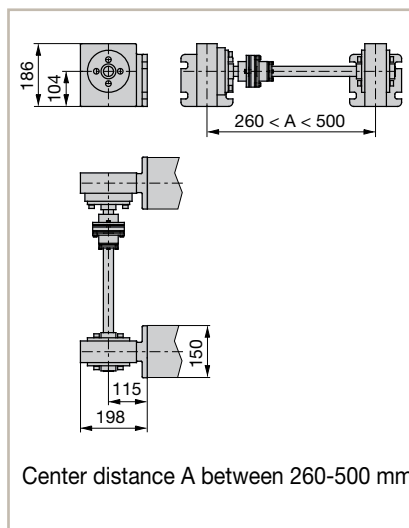
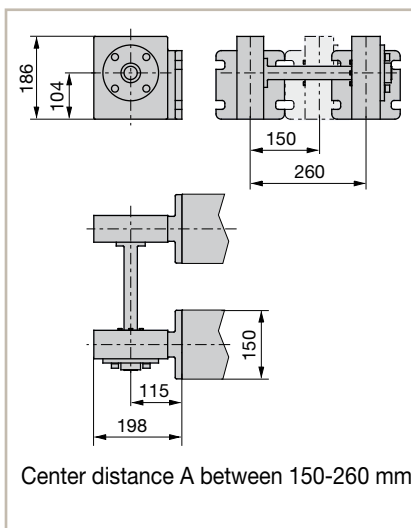

HLE150 -double axis with gearbox flange R (LEB150)

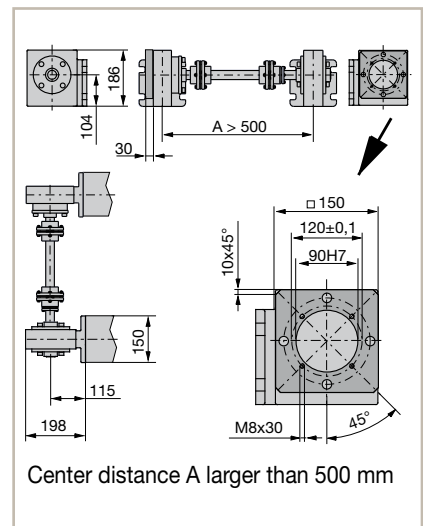
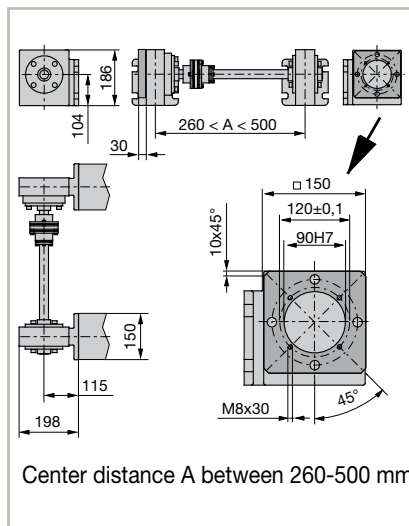
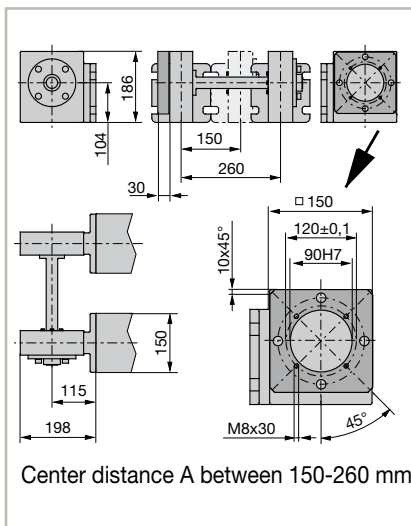

HLE - Idler Unit

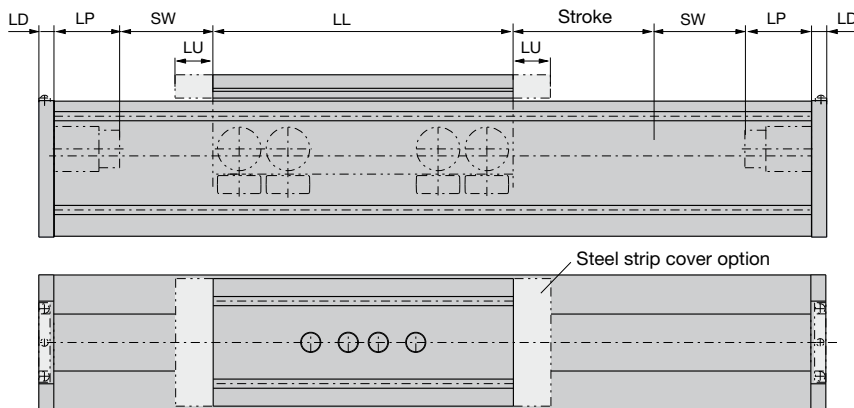

The HLE is also available as a driveless idler unit. In this case, it serves as a mere guiding. The profile cross section and carriage dimensions correspond to the dimensions of the actuators.

Axis type	Without steel strip cover					With steel strip cover				
	LD	LP	SW*	LU	LL	LD	LP	SW*	LU	LL
LEN100S/LEN100T	10	24	125	not applicable	300	10	69	125	35	300
LEN100E/LEN100F					450					450
LEN150S/LEN150T	10	36	125	not applicable	350	10	81	125	35	350
LEN150E/LEN150F					500					500

* SW = safety travel

Carriage with Bar

(Carriage T/F without load attachment plate; thread drawings for mounting the load)

For an HLE without load attachment plate, a bar is required as a replacement for the belt clamping. In order to attach your own loads, the threads in the carriage are accessible through bores in the strip.

HLE standard carriage with bar ((LEB100T/LEN100T))

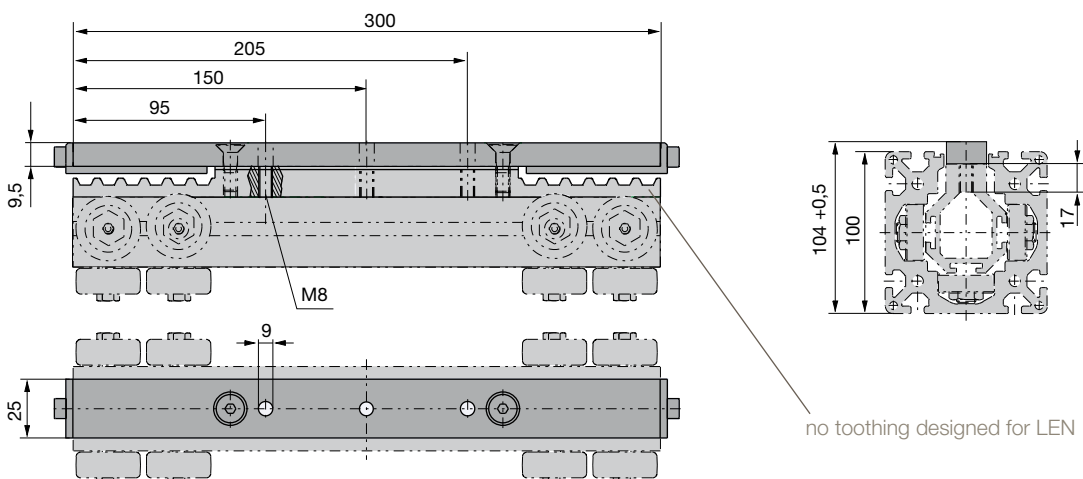

HLE extended carriage with bar (LEB100F/LEN100F)

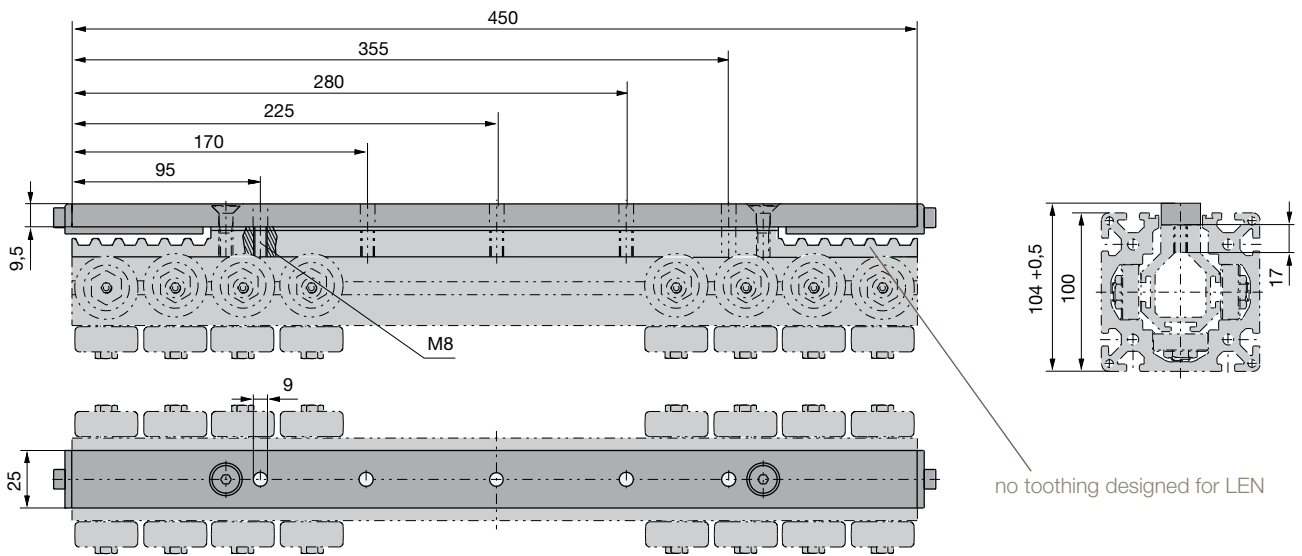

HLE standard carriage with bar (LEB150T/LEN150T)

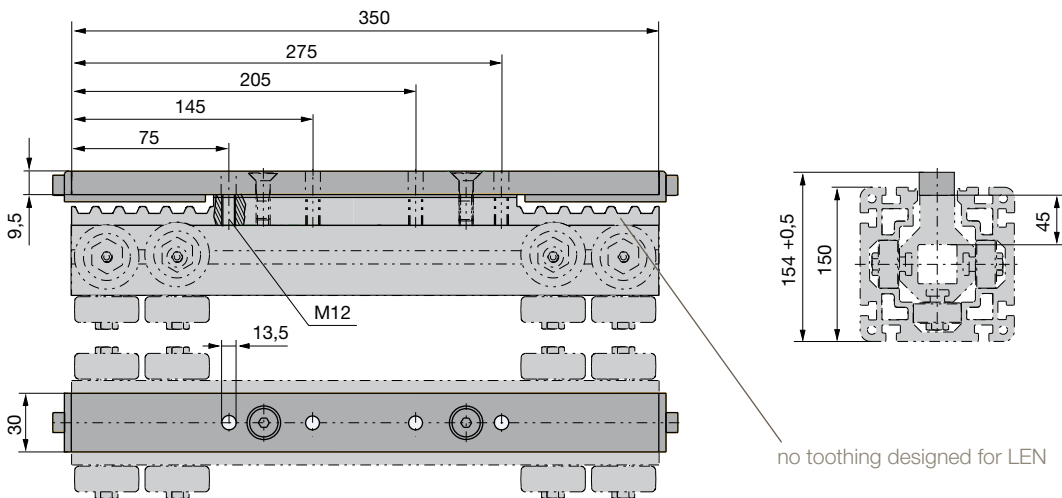

HLE extended carriage with bar (LEB150F/LEN150F)

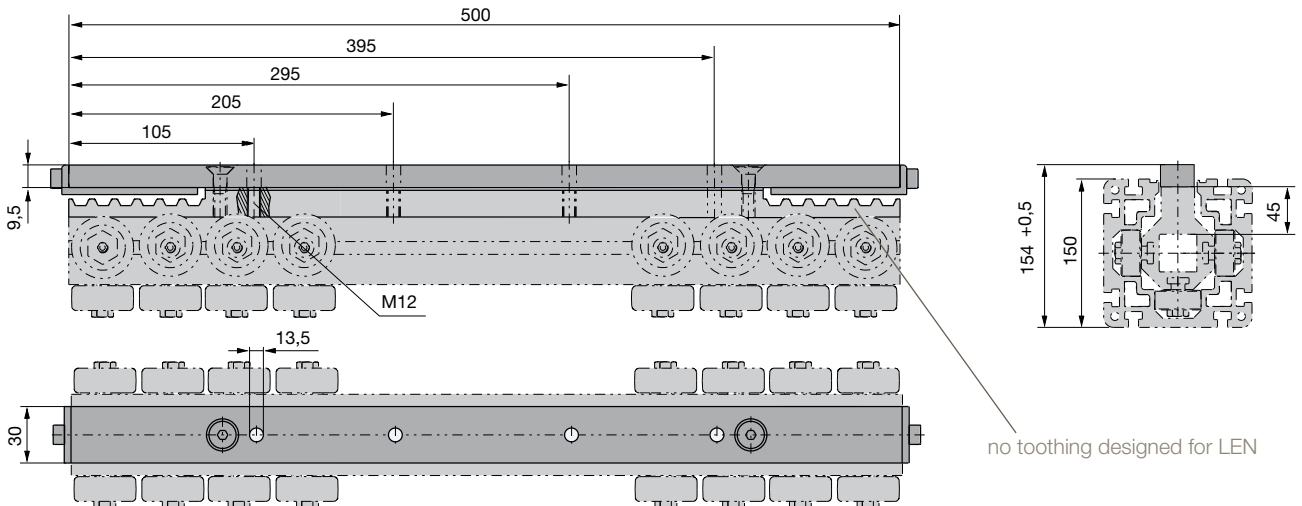

The HLEZ150 Linear System with Rack-and-Pinion Drive

- for long travels with consistently high stiffness and precision



The "unlimited" linear actuator

for guiding, moving and positioning, even over long travels, we offer:

- Long travels up to 50 m
- High speeds in practice up to 5 m/s
- High load bearing capacity horizontal up to 1000 kg / vertical up to 300 kg
- Transmissible drive torque max. 32 Nm
- Repeatability up to ± 0.05 mm
- Several carriages on a single actuator are possible
- Simple, fast mounting and commissioning

Typical areas of application

within the scope of innovative and cost-effective machine and system design:

- **Handling technology** e.g. palletizing, material feed and removal
- **Textile machine construction** e.g. cross-, length cutting and stacking, quilting, seaming
- **Process engineering** e.g. varnishing, coating, gluing
- **Stock technology** e.g. commissioning, stock-keeping
- **Construction technology** e.g. encasing, inserting steel reinforcements into concrete
- **Clean room technology** e.g. wafer transport, wafer coating
- **Machine tool manufacturing** e.g. charging of the work pieces, changing the tools
- **Testing technology** e.g. guiding of ultrasonic sensors

The combined technology

of the HLE linear actuator and rack offers the following advantages:

- High dynamic response, even over long travel distances, due to:
 - the short toothed belt regardless of travel length
 - the lightweight carriage
 - the backlash free drive
- High positional accuracy - regardless of stroke length
- Option of several carriages per linear actuator, making overlapping strokes along a single actuator possible
- Long inspection cycles, simple inspection
- Grooves running in the profiles on all sides to enable
- mounting of the HLEZ to a supporting structure, fitting attachments or as cable ducts
- Flexible installation options provided by longitudinal grooves in the load attachment plate.

The HLEZ - A Combined Technology

The new design

Taking the HLE linear actuators as its base, a new rack-and-pinion drive system has been designed for the LEB150.

The system which is especially suitable for long travel distances and high speeds, opens up a whole range of new applications options. The patented rack principle permits "endless" travel whilst maintaining high accuracy. At the same time, the dynamic characteristics of the system are outstanding.

When required, several carriages can be positioned on a single actuator independently of each other. In combination with other Parker mechanical components, this allows the construction of efficient and cost-effective gantry and automation systems.

Our experience

You can rely on our experience and skill, as over 25000 linear actuators are already in use throughout the world - whether it be in automatic textile equipment, handling systems, packaging machines, automatic painting and binding equipment, etc... The HLEZ is found across a broad application area - in clean rooms, in the food industry, in chemical production plants and in the production of precast concrete components. We cooperate with a wide range of different industrial sectors including the automotive industry, machine tool manufacturers, microelectronics manufacturers - and hopefully soon with you...

Examples/applications

- **Sick**, Waldkirch: Sensor testing equipment
- **Desarrollo**, Spain: Gantry robots for transporting glass fiber coils
- **Springs**, USA: Sewing textiles
- **Weckenmann**, Dormettingen: Wide-area gantry robots for the precast-concrete industry
- **AZO**, Osterburken: Marshalling equipment
- **EEW**, Schönberg: High-speed milling center
- **Telecom**, Switzerland: Telephone accessory order picking system
- **LT Engineering**, Switzerland: Shelf-picking unit for small parts stores
- **Allied Signal**, USA: Sewing airbags
- **Weber-Haus**, Linx: Boring and sawing cut-outs for the mounting of distribution boxes and socket outlets

HLEZ - Drive Principle

The HLEZ drive offers all the advantages of a toothed belt drive, without its typical disadvantages. The consistently short toothed belt, which is independent of the travel stroke, reduces belt stretch to a minimum. The lateral deflection rollers pre-

tension the system and eliminate the backlash. Contact rollers ensure that a sufficient number of teeth are in contact with the pulley. The combination of plastic timing belt with an aluminum rack is a safe and clean drive which does not require lubrication.

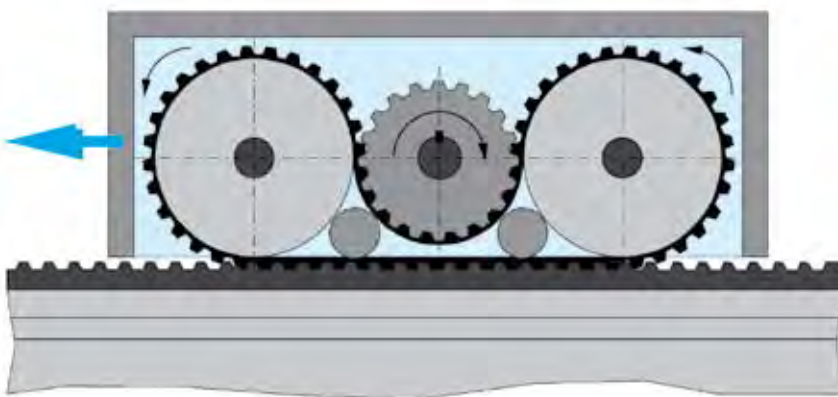

All of this offers the following advantages:

- high, consistent stiffness independent of the stroke length or position
- very long strokes are possible
- high precision
- high speeds are possible
- smooth, low-noise running
- no lubrication required
- any installation position possible

Construction of the HLEZ150

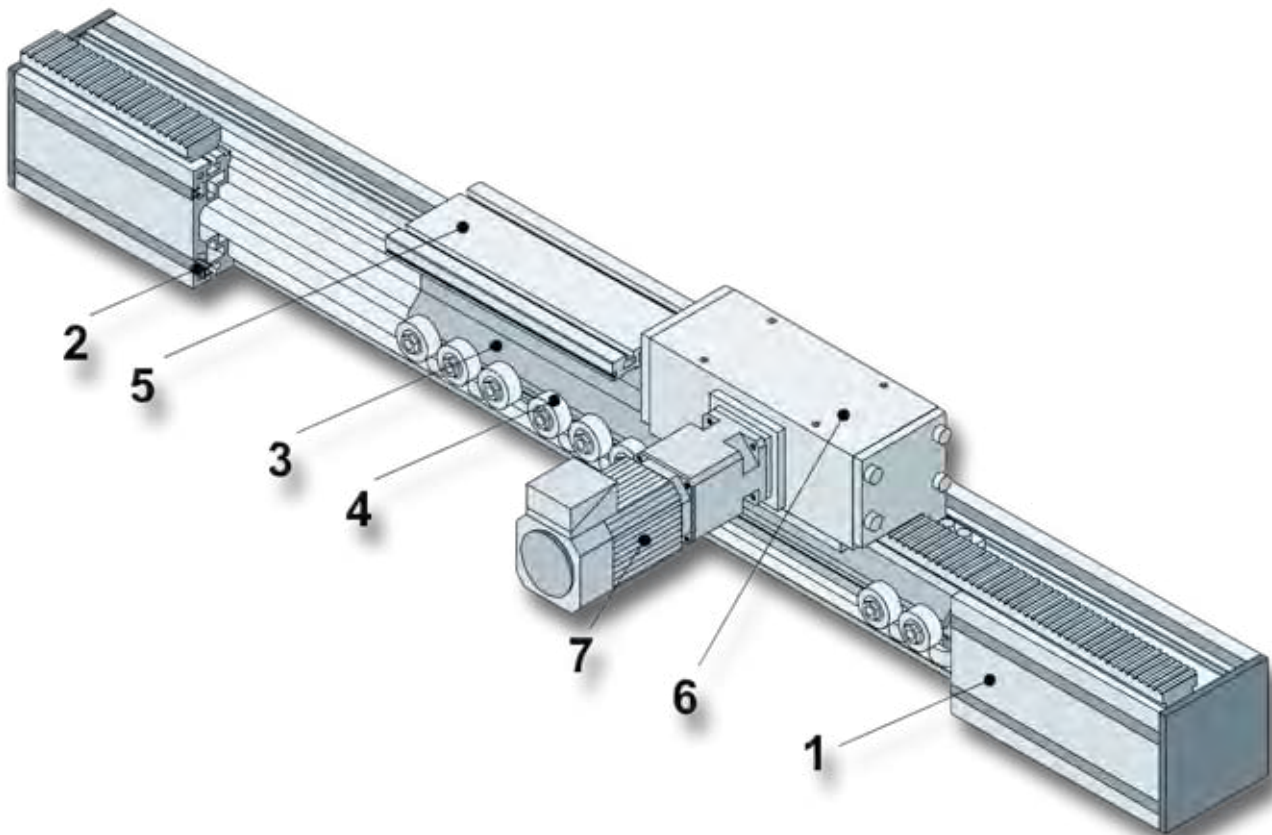

The profile (1)

Light, compact and self-supporting construction made from an aluminum profile. The profile features seven lengthwise clamping grooves for the attachment of additional mechanical components and for the connection of several HLEZ and HLE actuators. These grooves can also be used to attach initiators and mechanical switches. Together with the cover profile (2), these can be used as cable ducts.

The carriage (3)

Lightweight, rigid carriage with rolling-contact plastic bearings (4) and eccentric axes for a backlash-free alignment of the carriage in all directions. Overall, this results in high mechanical efficiency and virtually wear-free operation. The carriage can be supplied in two lengths either standard or extended. Customer-specific special carriages are available on request.

The load attachment plate (5)

Many possibilities to mount parts by integrated longitudinal grooves at the upper side of the plate. In connection with the clamping profiles (page 33), this allows an easy integration into multi-axis systems. Simple and variable attachment of operating cams or switch lugs is provided by longitudinal grooves placed on the sides or underneath the plate. Special versions are available on request.

The drive module (6)

Compact drive module, can be optionally supplied fitted on either side of the load attachment plate. Description of the drive principle: see on page 25. Parker servo motor (7) with resolver and appropriate planetary gearbox form the optimum drive for dynamic and precise applications. In connection with the compact Com-pax3 servo drive, you can dispose of a complete, plug-in automation system for single and multi axis linear- and path control.

Technical Data

HLEZ - Size	Unit	150
Weights and mass moments of inertia		
Weight of base unit without stroke		
HLEZ with standard carriage	[kg]	53
HLEZ with extended carriage	[kg]	61
Mass of standard carriage load attachment plate and drive module	[kg]	25.7
Mass of extended carriage with load attachment plate and drive module	[kg]	29.7
Mass per meter of additional length (guiding profile + rack)	[kg/m]	23.9
Mass moment of inertia with respect to the drive shaft ¹ (taken into consideration: carriage with load attachment plate and drive module)		
Standard carriage S	[kgcm ²]	325
Extended carriage E	[kgcm ²]	363.4
Strokes, travel speeds and efficiency		
Maximum travel speed	[m/s]	5.0
Maximum stroke, standard carriage S/T ² with one profile	[mm]	8888
Maximum stroke, extended carriage E/F ² with one profile	[mm]	8738
Maximum stroke with longitudinal flange(s) ³	[mm]	50000
Efficiency	[%]	85
Overall dimensions and physical data of guiding profile		
Cross-section	[mm x mm]	150 x 150
Moment of inertia I _x	[cm ⁴]	1940
Moment of inertia I _y	[cm ⁴]	2147
Moment of inertia I _t	[cm ⁴]	391
E-modulus (aluminum)	N/mm ²	0.72 x 10 ⁵
Pulley data, torques and forces		
Travel distance per revolution	[mm/rev]	200
Pulley diameter of drive pinion (D _A)	[mm]	63.66
Number of teeth of drive pinion		20
Toothed belt width/pitch	[mm]	50 / 10
Drive torque	[Nm]	32
Thrust force	[N]	1000
Repeatability ⁴	[mm]	± 0.05



Please contact Parker if your application has the following requirements!

- ¹ Additional mass moment of inertia caused by the payload: $J_{\text{payload}} = m_{\text{payload}} \times \frac{1}{4} DA^2$
(motor and gear weight are added to the payload).
- ² Longitudinal flanges possible in order to obtain longer strokes (see on page 34).
- ³ The travel is unlimited by the linear actuator - it depends however on the energy supply of the drive.
- ⁴ Applies for the linear actuator with drive module, without drive.

→ Safety factor taken into consideration S=1. Data applies for a temperature range of between -10°C and +40°C

HLEZ Toothed Belt Load Bearing Capacity

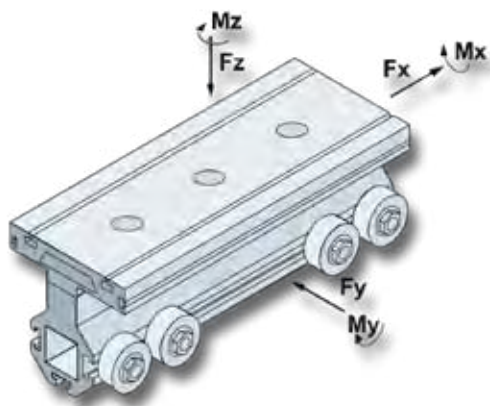

Forces and torques transferred by the carriage are speed-dependant. The graphs shown in the diagrams only apply to standard carriages (S/T). In the case of extended carriages (E/F), all values can be doubled if the load is introduced in pairs or evenly over the entire length of the carriage.

The curves show the maximum load-bearing capacity of a carriage in one direction of force or torque. If several loads are applied in different directions, the values specified in the curves **must be derated**, i.e. the load or speed should be reduced if necessary.

For precise dimensioning, our software "DimAxes" is available (calculation identical to HLE150) (see "Other Accessories / Software" on page 44).

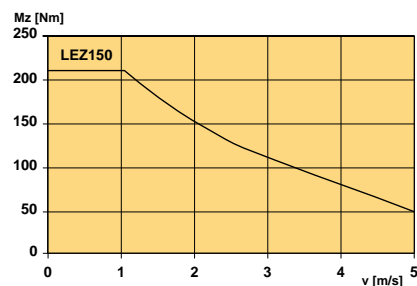
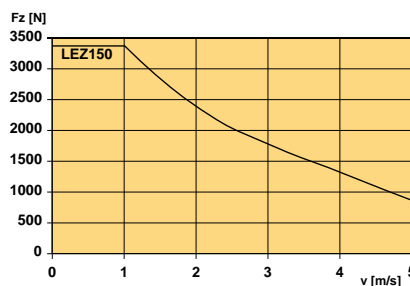
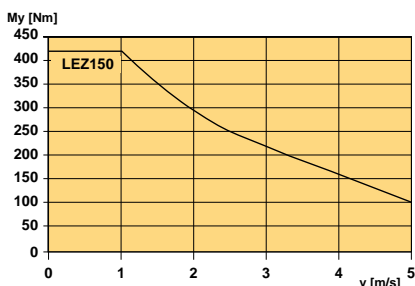
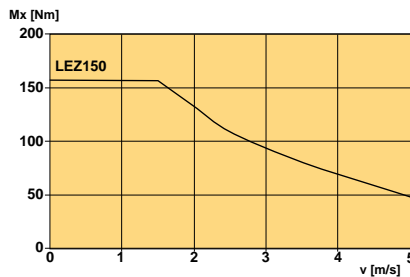
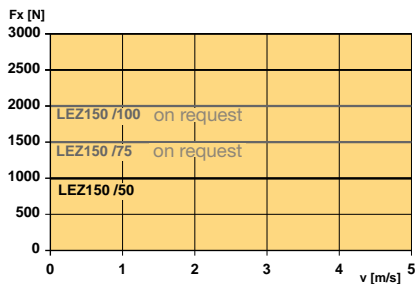

HLEZ150 Dimensional Drawing

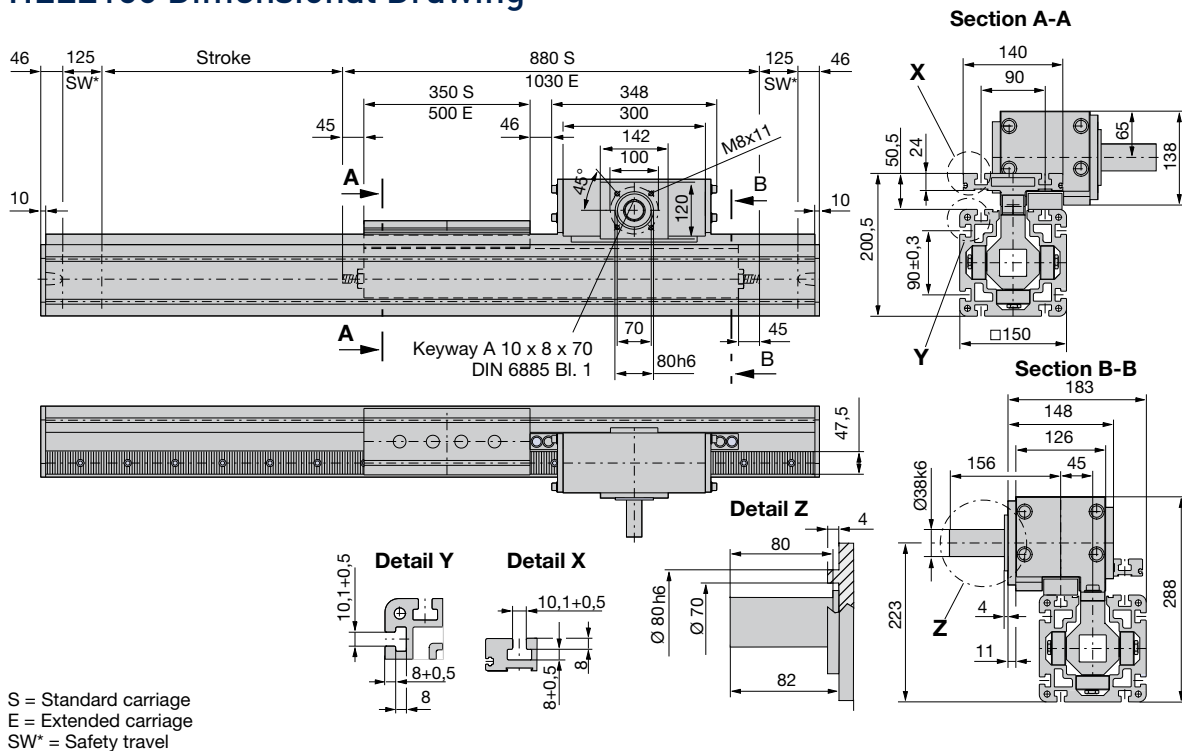

Gearbox fitting - Examples

HLEZ150 with planetary gearbox PL5-OP11 or PE5 (LEZ150)

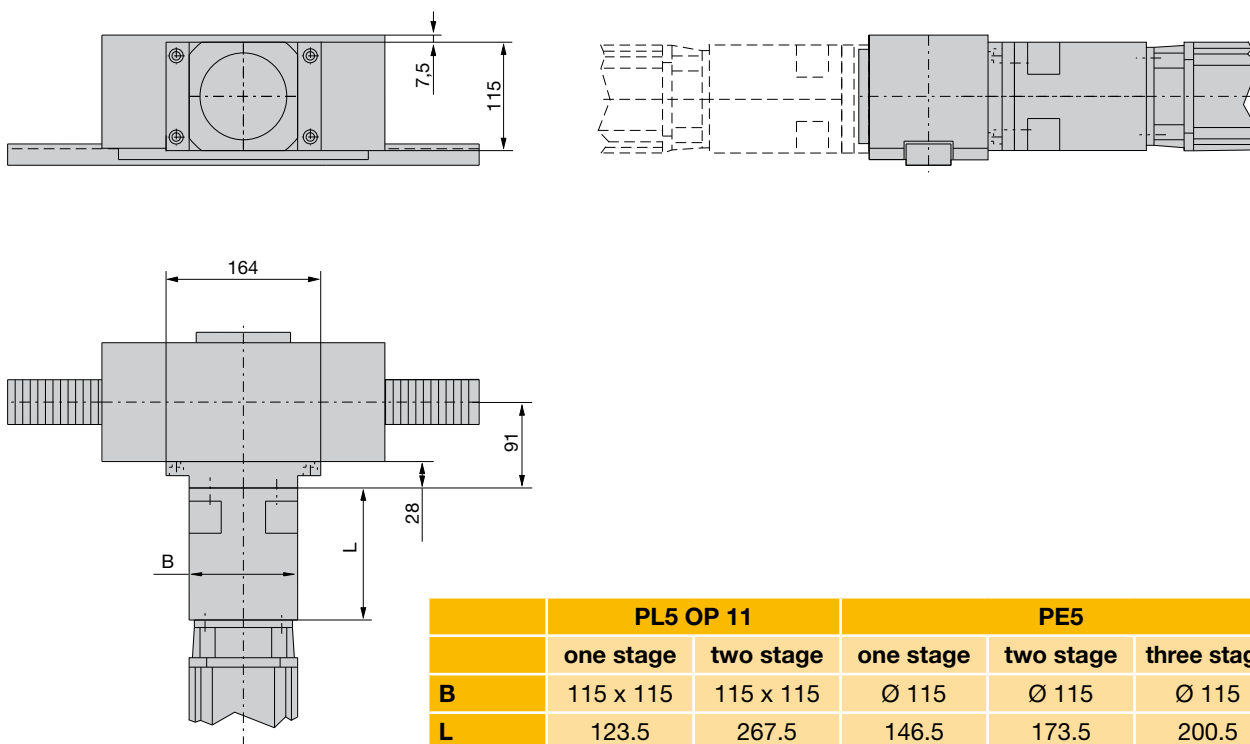

¹ Available range of transmission

HLEZ150 with worm gearbox (LEZ150)

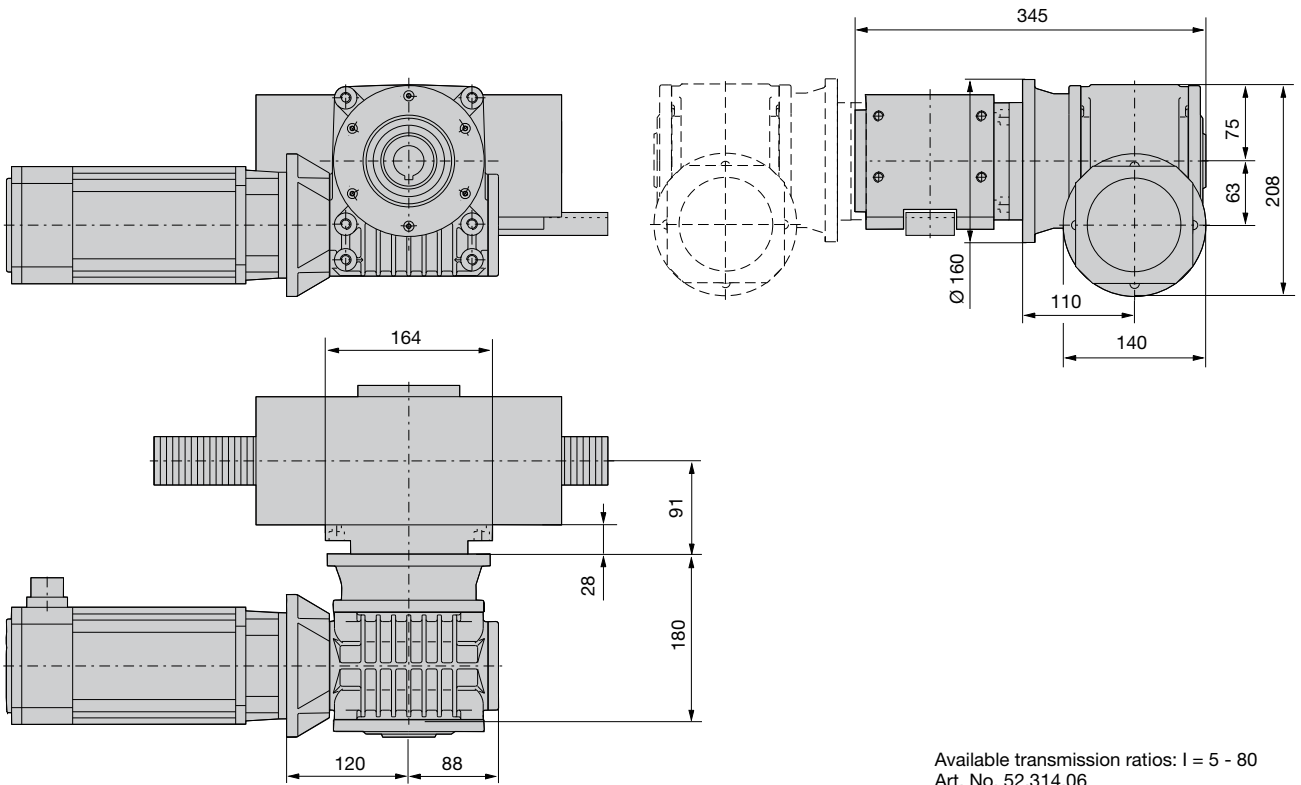

Available transmission ratios: $i = 5 - 80$
Art. No. 52.314.06

Accessories

Dimensions in [mm]
Schematic representation

Assembly Angle Plate

The assembly angle plate is used to attach a HLE or a HLEZ

- to another linear actuator
- with a base (a Parker profile can be used as support)
- to other machine components

It is available in different sizes, isosceles or scalene - each with through holes.

Assembly angle plate isosceles

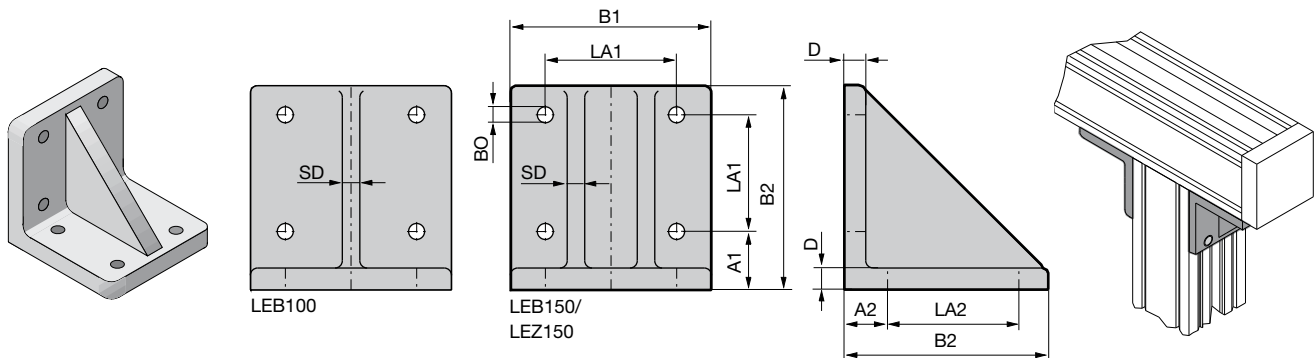

Frame size	Type	A1	A2	B	B1	B2	D	LA1	LA2	SD	Art. No.
LEB100	MWD 90/90	20	30	Ø9	88	90	10	60	50	10	500-000512
LEB150/LEZ150	MWD 140/140	30	40	Ø11	138	140	15	90	80	12	500-000523

Assembly angle plate scalene

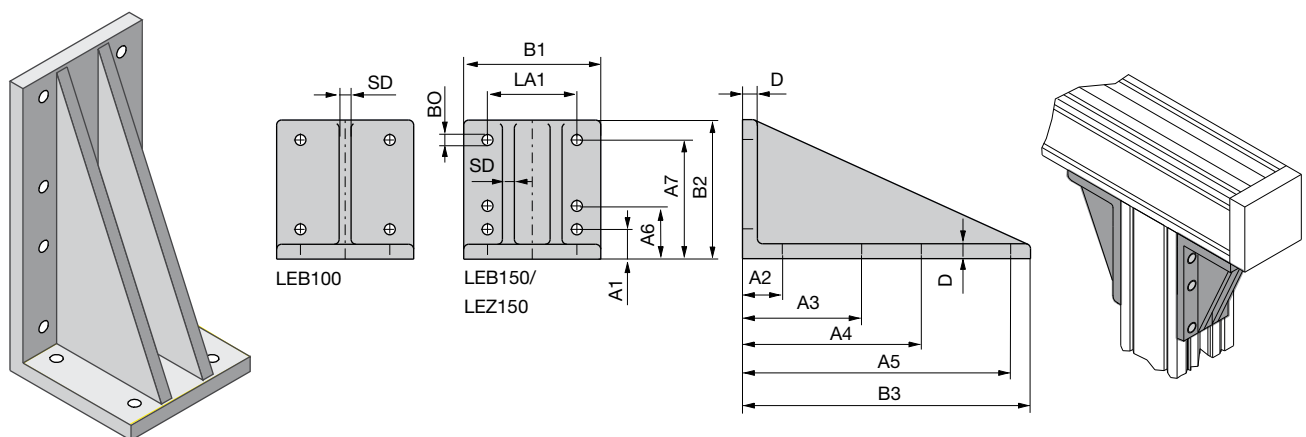

Frame size	Type	A1	A2	A3	A4	A5	A6	A7	BO	B1	B2	B3	D	LA1	SD	Art. No.
LEB100	MWD 90/190	20	30	80	120	180	--	80	Ø9	88	90	190	10	60	10	500-000513
LEB150/LEZ150	MWD 140/290	30	40	120	180	270	55	120	Ø11	138	140	290	15	90	12	500-000524

T-Nuts/Bolts

The T nuts and bolts can be used to attach other components in the T-slots of the profile, or on the upper side of the load attachment plate.

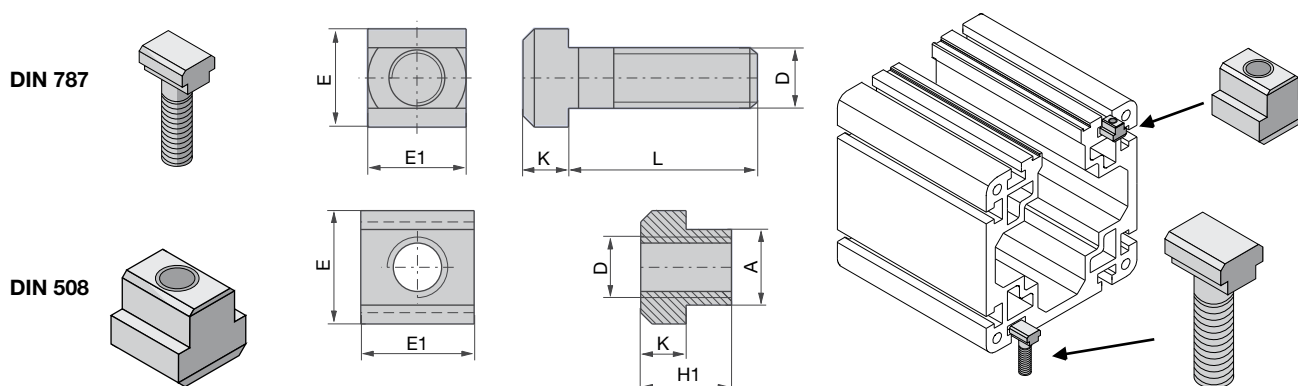

Frame size	Designation		A	D	E	E1	H1	K	L	Art. No. (stainless)
LEB100	T-Bolt	DIN787 M8x8x25	--	M8	13	13	--	6	25	131-700001
LEB100	T-Bolt	DIN787 M8x8x32	--	M8	13	13	--	6	32	131-700002 (135-725450)
LEB100	T-Bolt	DIN787 M8x8x40	--	M8	13	13	--	6	40	131-700003
LEB150 / LEZ150	T-Bolt	DIN787 M10x10x25	--	M10	15	15	--	6	25	131-700007 (135-725459)
LEB150 / LEZ150	T-Bolt	DIN787 M10x10x32	--	M10	15	15	--	6	32	131-700008 (135-725460)
LEB150 / LEZ150	T-Bolt	DIN787 M10x10x40	--	M10	15	15	--	6	40	131-700009 (135-725465)
LEB150 / LEZ150	T-Bolt	DIN787 M10x10x63	--	M10	15	15	--	6	63	131-700011
LEB100	T-Bolt	DIN508 M6x8	8	M6	13	13	10	6	--	131-700103 (135-725400)
LEB150 / LEZ150	T-Bolt	DIN508 M8x10	10	M8	15	15	12	6	--	131-700104 (135-725402)
LEB100	Long nut*	HWN313 M6x8	8	M6	13	26	10	6	--	131-700140
LEB150 / LEZ150	Long nut*	HWN313 M8x10	10	M8	15	30	12	6	--	131-700141 (135-725406)
LEB100	Nut	ITEM St M6	without drawing						400-00033 (400-00032)	
LEB150 / LEZ150	Nut	HWN314 M8x10	Rhombus form for retro-fitting						131-700155	

* When using the combination of two linear actuators via clamping profiles, we would recommend the use of long nuts.

Toe Clamp

The toe clamps are used in conjunction with the standard load attachment plate to rapidly install and attach various combinations of linear actuators. Two clamping profiles are needed to fix a HLE/HLEZ/HPLA on a flange plate. The following table shows the required profiles for the different axis combinations:

top bottom	LB..080 (HPLA80)	LE..100 (HLE100)	LB..120 (HPLA120)	LE..150 (HLE150)	LB..180 (HPLA180)
LB..080	Art. No. 500-000931	--	--	--	--
LE..100	Art. No. 500-000932	Art. No. 500-000905	--	--	--
LB..120	Art. No. 500-000930	Art. No. 500-000908	Art. No. 500-000925	--	--
LE..150	--	Art. No. 500-000903	Art. No. 500-900909	Art. No. 500-000902	--
LB..180	--	--	Art. No. 500-000922	Art. No. 500-000921	Art. No. 500-000920

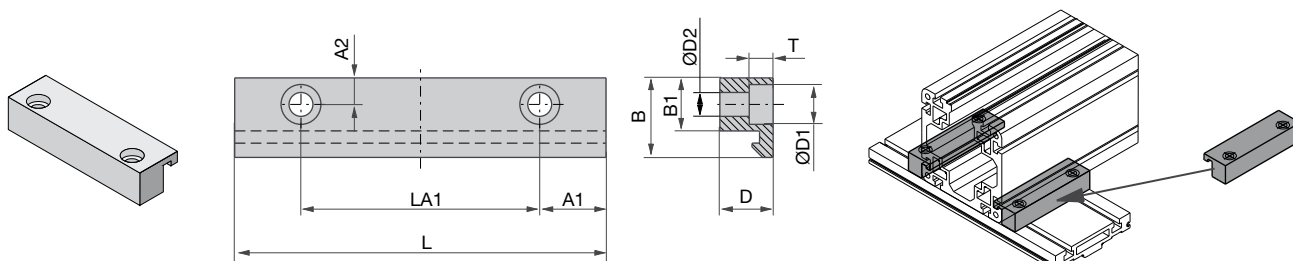

Art. No.	A1	A2	B	B1	D	D1	D2	L	LA1	T
500-000902	25	12	40	25	30	15	9	140	90 ±0.2	9
500-000903	25	10	30	20	20	15	9	140	90 ±0.2	9
500-000905	15	10	30	20	20	11	6.6	90	60 ±0.2	7
500-000908	20	10	30	20	20	15	9	110	70 ±0.2	9
500-000909	25	12.5	37.5	25	26	15	9	140	90 ±0.2	9
500-000920	30	15	45	30	36	18	11	170	110 ±0.2	11
500-000921	30	12	40	25	30	18	11	170	110 ±0.2	11
500-000922	25	12.5	37.5	25	26	18	11	160	110 ±0.2	10.6
500-000925	20	12.5	37.5	25	26	15	9	110	70 ±0.2	9
500-000930	20	10	27	20	17	15	9	110	70 ±0.2	9
500-000931	14	10	27	20	17	10	5.5	76	48 ±0.2	5.7
500-000932	15	10	27	20	17	15	9	90	60 ±0.2	9

External Stop Buffer

The external stop buffer is mounted in the grooves of the HLE/HLEZ profile and can be adjusted infinitely.

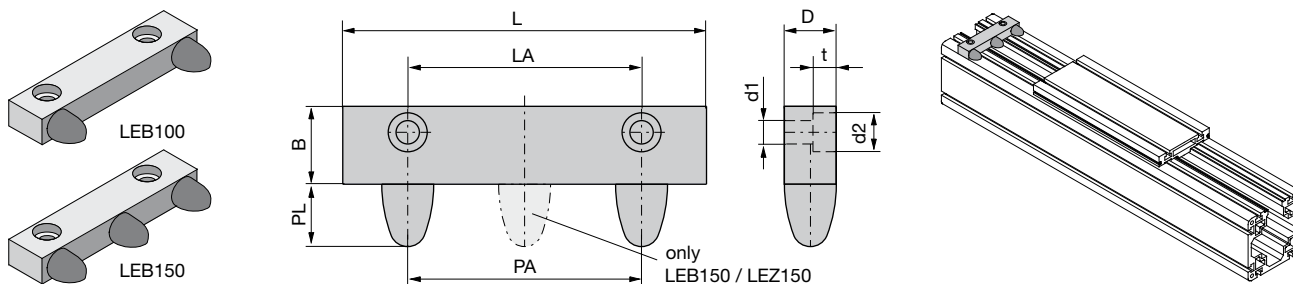

Frame size	Type	B	D	d1	d2	L	LA	PA	PL	t	Part No. (including 2 matching socket head screws and t-nuts)
LEB100	EAP100	30	20	Ø 6.6	Ø 11	90	60	40	24	6.8	510-001285
LEB150 / LEZ150	EAP150	30	20	Ø 9	Ø 15	140	90	90	24	9	510-001385

Longitudinal Flange Set

The working stroke can be more than doubled when using the flange plates. A longitudinal flange is required if the travel path exceeds the profile length (see: technical data, page 16 and 27): The separation of the profiles is made, if possible and not stated otherwise, in the middle. The cut-off point of the longitudinal flanges should always be located near a fixation point. The support distance should be between 1.0 m and 1.5 m. For a HLE with toothed belt drive and longitudinal flanges, the load characteristics must be derated (if the maximum travel is exceeded, see technical data, page 16) and it should only be used with the profile opening at the top or at the bottom.

	Unit	LEB100	LEB150	LEZ150
maximum permissible load	[N]	$0.5 \times F_x^{*1}$	$0.5 \times F_x^{*1}$	unchanged (see on page 27)
Speed	[m/s]	< 1	< 1	
Acceleration	[m/s ²]	< 1	< 1	
Repeatability	[mm]	> ±0.5	> ±0.5	

*1. Fx-HLE: see on page 16

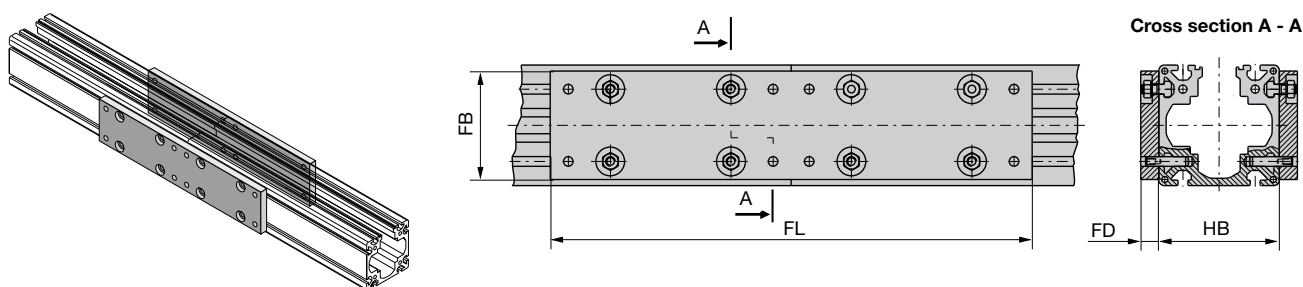

Frame size	Type	FL	FB	FD	HB
LEB100	LVS100	400	90	15	100
LEB150 / LEZ150	LVS150	500	130	15	150

Intermediate Shaft Bearing for HLE Double Axes

The intermediate shaft bearing is used to support the connection shaft of a HLE double axis in the event of a long axis distance. The intermediate shaft bearing must be used if the critical rotational speed (see diagram on the left) is exceeded with the double actuator connection shaft:

Critical rotational speed

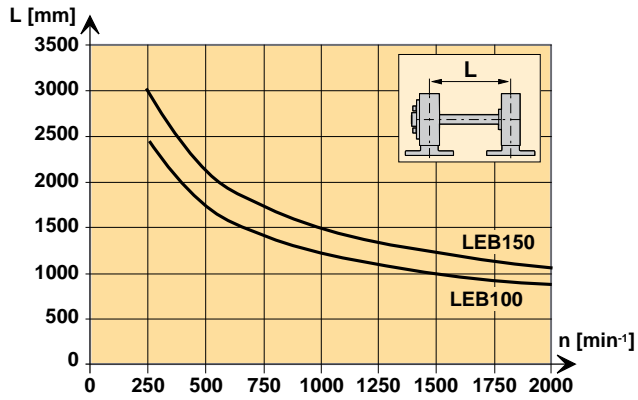

Ratio of rotational speed and speed

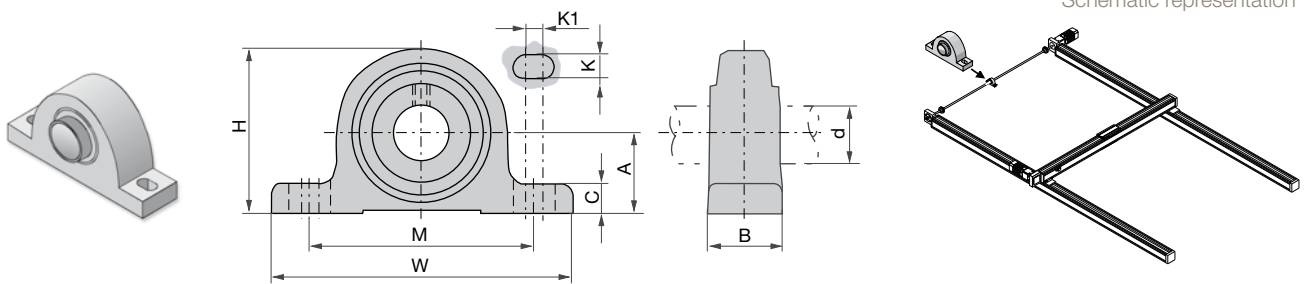
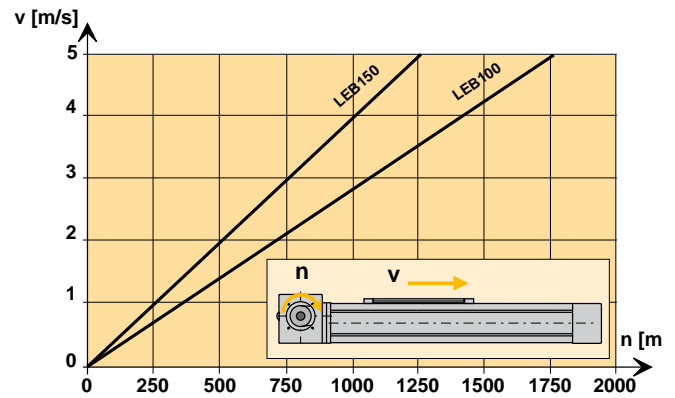

Frame size	Type	A	B	C	d	H	K	K1	M	W	Art. No.
LEB100	PASE20	33.3	32	14.5	Ø20	64	11	8	97	130	416-000120
LEB150	PASE30	42.9	40	17	Ø30	82	14	8	118	158	416-000160

Position Switch Attachment / electronic accessories

Mounting configurations of the position switch



As a standard, tripping plate, switches and distribution box are mounted on the motor side. The limit switches are fitted ensuring that they are activated directly before the start of the standard safety travel (125 mm). Unless otherwise agreed, the linear actuator is supplied with position sensors attached using attachment variant 1 or 2. The tripping plates, position sensors and distribution box are described on pages 37 et seqq.

Attachment variant 1: HLE/HLEZ with 3 electrical initiators

This is the standard initiator attachment variant.

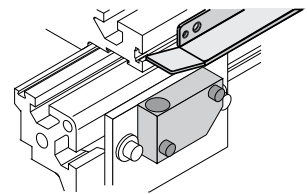
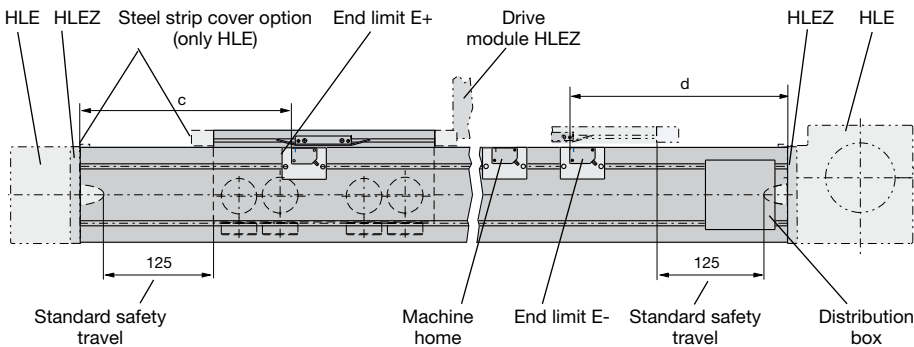

Size	Unit	Standard HLE				HLE with steel strip cover LEB100				HLEZ	
		LEB100		LEB150		LEB150				LEZ150	
		S/T	E/F	S/T	E/F	S/T	E/F	S/T	E/F	S/T	E/F
c	[mm]	248	323	285	360	293	368	330	405	330	405
d	[mm]	260	335	297	372	305	380	342	417	782	857

The tripping plate is enclosed separately into the delivery for the carriage configuration with bar (T/F)

Mounting configuration 2: HLE with 2 mechanical limit switches and an electrical home sensor

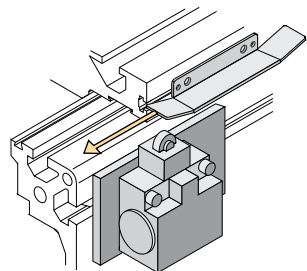
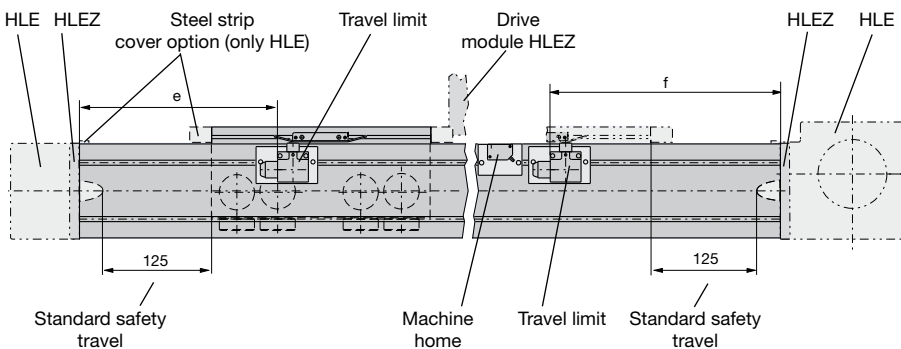

Size	Unit	Standard HLE				HLE with steel strip cover LEB100				HLEZ	
		LEB100		LEB150		LEB150				LEZ150	
		S/T	E/F	S/T	E/F	S/T	E/F	S/T	E/F	S/T	E/F
e	[mm]	229	304	266	341	274	349	311	386	311	386
f	[mm]	280	355	317	392	325	400	362	437	802	877

The tripping plate is enclosed separately into the delivery for the carriage configuration with bar (T/F)

Mounting configuration 4: HLE with 1 mechanical limit switch and an electrical home sensor, both moving along

This variant is preferred in robotic systems, if the supply of the switches is made via the cable carrier. The tripping plates must be mounted so that the mechanical switch is actuated immediately before the beginning of the safety travel.

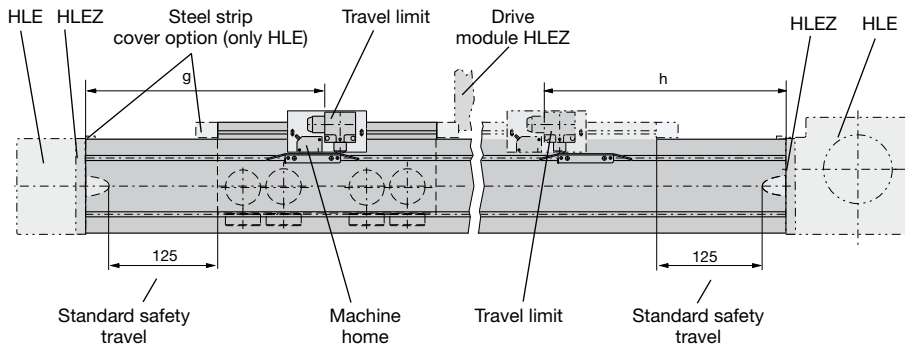

Size	Unit	Standard HLE				HLE with steel strip cover LEB100				HLEZ	
		LEB100		LEB150		LEB100		LEB150		LEZ150	
		S/T	E/F	S/T	E/F	S/T	E/F	S/T	E/F	S/T	E/F
g	[mm]	295	370	332	407	340	415	377	452	377	452
h	[mm]	312	387	349	424	357	432	394	469	825	900

The initiator and the limit switch are enclosed separately into the delivery for the carriage configuration with bar (T/F).

Tripping plate

The tripping plate is suitable for all standard load attachment plates. It is fixed to the load attachment plate with the aid of cylinder head screws and square nuts.

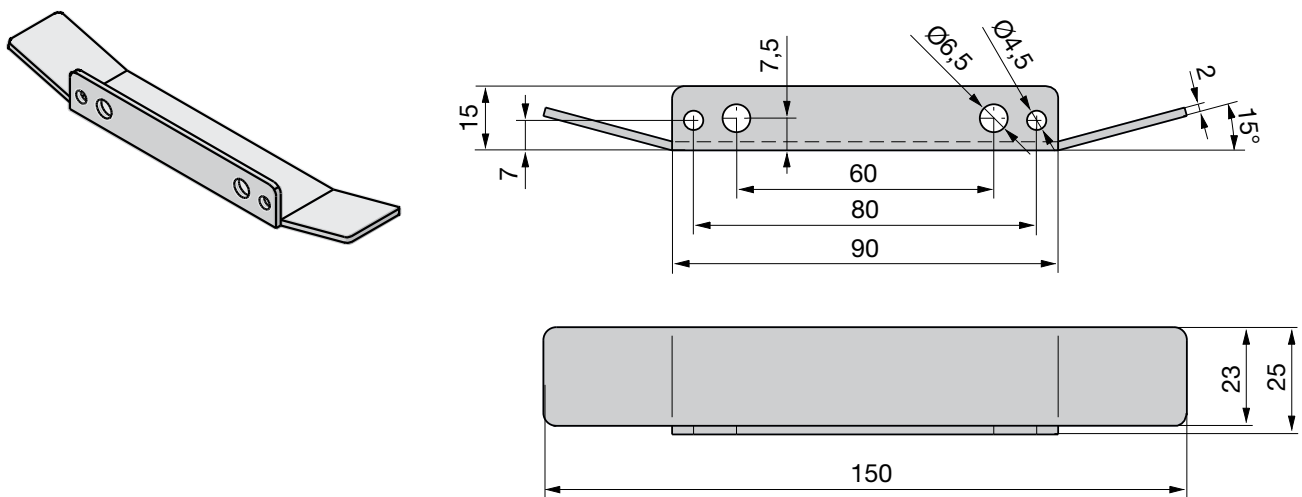

- Art. No. Tripping plate: 500-000531
- Order No. Square nut (2 pcs. required): 135-700001
- Art. No. Cylinder head screw M4x6 (2 pcs. required): 130-302294

Mechanical limit switch

The limit switch corresponds to DIN EN 50047. The contacts satisfy the safety requirements by forced opening in accordance with EN 60947-5-1.

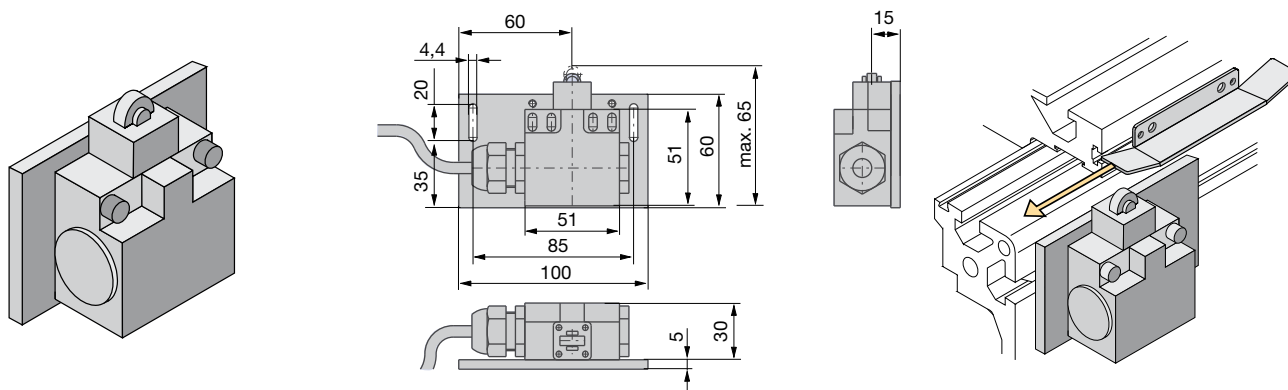

Type	Designation	Art. No.
LE..100	Mechanical limit switch with fixing material (Plate, nuts, bolts and washers)	510-900500
LE..150	Mechanical limit switch with fixing material (Plate, nuts, bolts and washers)	510-900505

Electrical initiators

The initiators are activated by a tripping plate on the side on the flange plate.

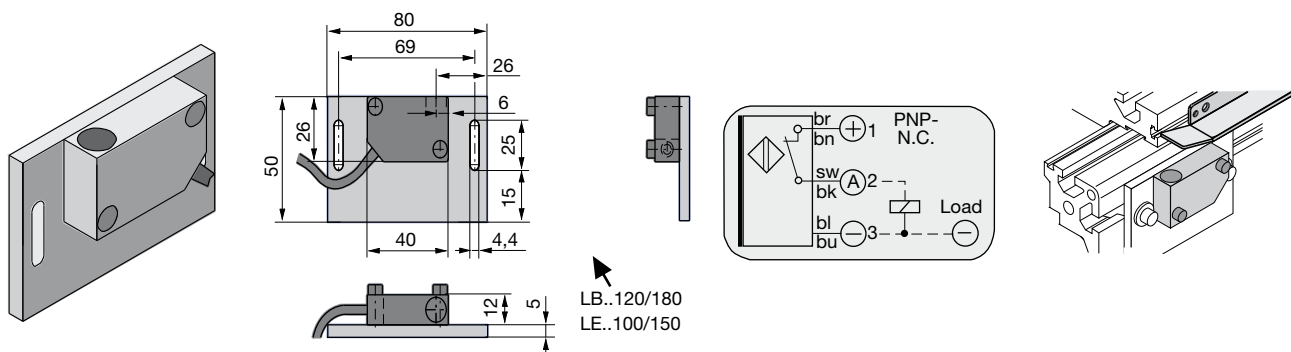

Technical data		Electrical data	
Switching distance	2mm / 4mm ± 10%	Rated Voltage	24 V DC
Switch hysteresis	> 1% ... < 15%	Voltage range	10...35 V DC
Repeatability	0.01 mm	Supply current	< 15 mA
Temperature drift	< 10 %	Maximum load current	300 mA
Ambient temperature	-25°C - +70°C	Residual voltage	< 2.5 V DC
Protection class	IP67	Switching frequency	2 kHz
Cable length	6 m	Connecting cables	3 x 0.25mm ²

Type	Designation	Part number	
		Standard design	Stainless version
LE..100	Electrical limit switch NPN normally closed contact with 6 m cable and fixing material	510-900522	510-900632
LE..100	Electrical limit switch NPN normally open contact with 6 m cable and fixing material	510-900520	510-900630
LE..100	Electrical limit switch PNP normally closed contact with 6 m cable and fixing material	510-900600	510-900631
LE..100	Electrical limit switch PNP normally open contact with 6 m cable and fixing material	510-900523	510-900633
LE..150	Electrical limit switch NPN normally closed contact with 6 m cable and fixing material	510-900527	510-900622
LE..150	Electrical limit switch NPN normally open contact with 6 m cable and fixing material	510-900525	510-900620
LE..150	Electrical limit switch PNP normally closed contact with 6 m cable and fixing material	510-900602	510-900621
LE..150	Electrical limit switch PNP normally open contact with 6 m cable and fixing material	510-900528	510-900623

Distribution box



Only for limit switch attachment variant 2

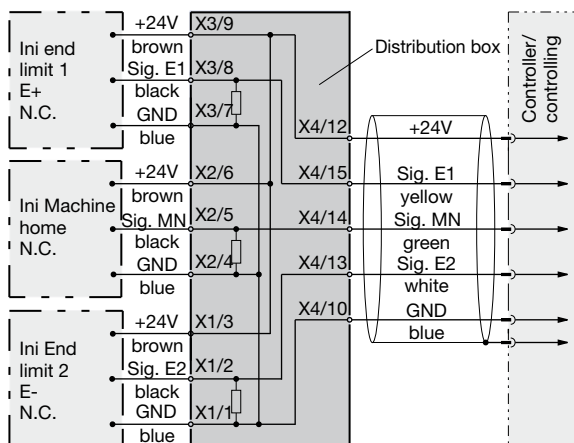
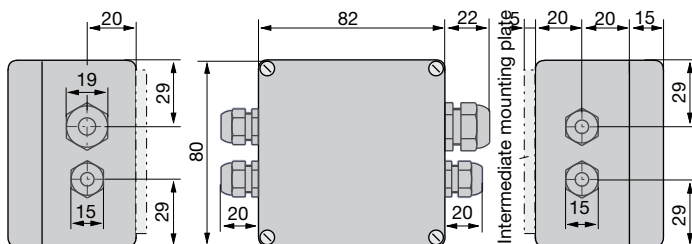

Designation	Part number
Distribution box including 2.5 m cable	800-003102
Distribution box including 5 m cable	800-003103
Distribution box including 7.5 m cable	800-003104
Distribution box including 10 m cable	800-003105
Distribution box including 12.5 m cable	800-003106
Distribution box including 15 m cable	800-003107
Distribution box including 20 m cable	800-003108
Distribution box including 25 m cable	800-003109
Distribution box including 30 m cable	800-003110
Distribution box including 35 m cable	800-003111
Distribution box including 40 m cable	800-003112
Distribution box including 45 m cable	800-003113
Distribution box including 50 m cable	800-003114

Frame size	Designation (Art. No. of the distribution boxes: see table above)	Art. No.	
		Standard	Stainless version
LB..080	Attachment components for distribution box	510-900710	510-900712
LB..120	Attachment components for distribution box	510-900612	510-900613
LB..180	Attachment components for distribution box	510-900670	510-900672

Cable Carrier

A cable carrier is needed when making power connections to moving elements. The cable carrier chain consists of Igu-mid® and the support profile is made of aluminum.



The process for fully determining the dimensions of a cable carrier is very complex. The examples listed below represent simple applications, but more data will normally be required when the situation is less straightforward. **The following descriptions are only valid for cable carriers in horizontal configuration supported by a profile - within the limits stated in the technical specifications.** If your application is more complicated, please contact us.

Dimensions of supporting profile and carrier chain

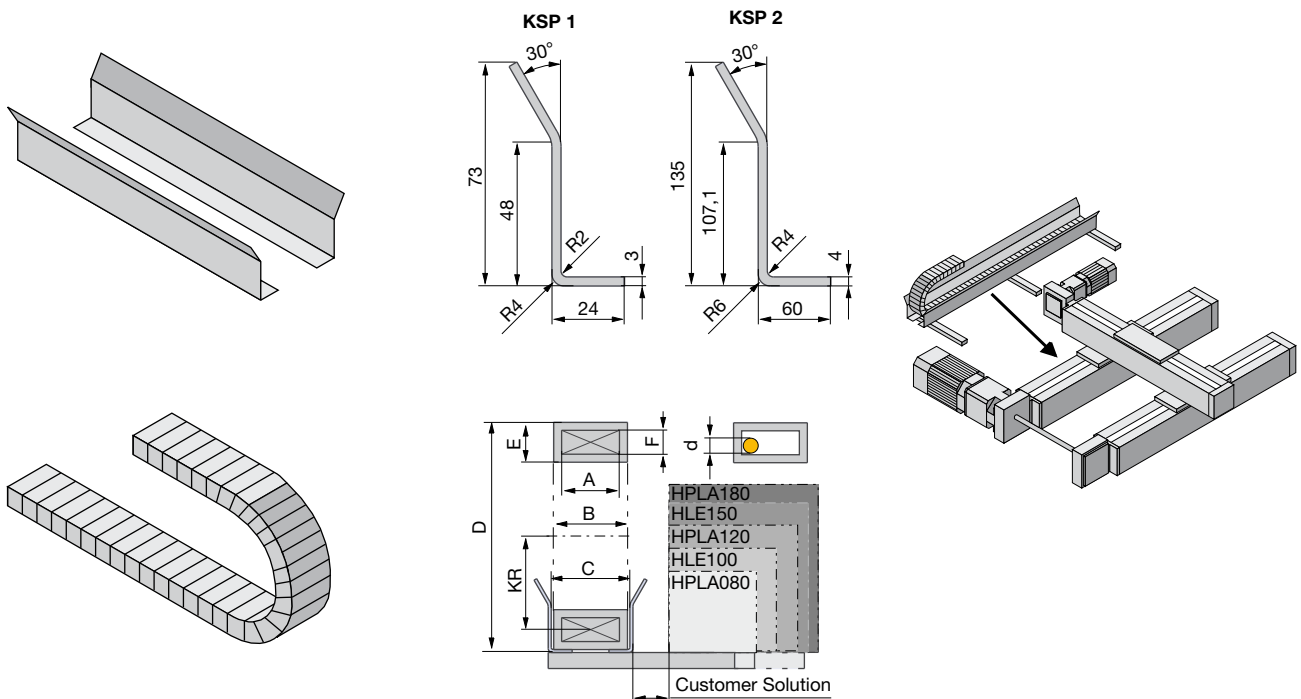

	Type	KR	A	B	C	D max.	E	F	d max.	Art. No. (Length, see chapter: Determination of the chain length)	
										Cable carrier chain	Connection elements fix point and driving plate (inelastic) (please refer to the next page)
with KSP1	B15.015.038.0	38	15	26	31	120	23	17.5	14	100-905150	100-905006
	B15.025.038.0	38	25	36	41	120	23	17.5	14	100-905170	100-905178
	2500.03.055.0	55	38	54	61	170	35	25	23	100-905810	100-905818
	2500.03.100.0	100	38	54	61	260	35	25	23	100-905830	100-905838
	2500.05.100.0	100	57	73	78	260	35	25	23	100-905850	100-905858
	2500.07.150.0	150	77	93	98	360	35	25	23	100-905860	100-905868
with KSP2	2700.07.200.0	200	75	91	96	485	50	35	32	100-905861	100-905869
	2700.12.200.0	200	125	141	146	485	50	35	32	100-905921	100-905928
	2700.17.200.0	200	175	194	199	485	50	35	32	100-905960	100-905968
KSP1 small cable supporting profile (Please state required length. Length = stroke)										400-010120	
KSP2 large cable supporting profile (Please state required length. Length = stroke)										400-010121	

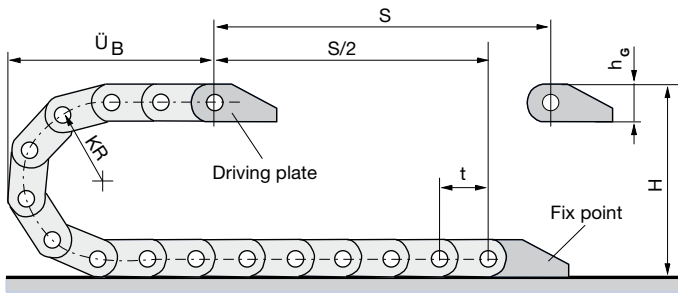

Dimensional drawings of the connection elements (fixed point and driving plate, both inelastic): see on the next page

Type	Bending radius KR	Pitch t	Height h_g	Curve protrusion \ddot{U}_B	Connection height H	Clearance mounting height H_F	Own chain weight [kg/m]
B15.015.038.0	38	30.5	23	80	100	120	≈ 0.35
B15.025.038.0	38	30.5	23	80	100	120	≈ 0.40
2500.03.055.0	55	46	35	125	145	170	≈ 0.81
2500.03.100.0	100	46	35	170	235	260	≈ 0.81
2500.05.100.0	100	46	35	170	235	260	≈ 0.90
2500.07.150.0	150	46	35	220	335	360	≈ 1.01
2700.07.200.0	200	56	50	275	450	485	≈ 1.30
2700.12.200.0	200	56	50	275	450	485	≈ 1.48
2700.17.200.0	200	56	50	275	450	485	≈ 1.85

Dimensional drawings of the connection points

for type B15.xxx

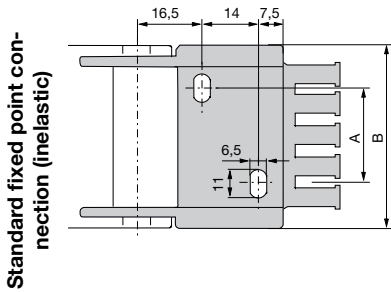

for type 2500.xxx

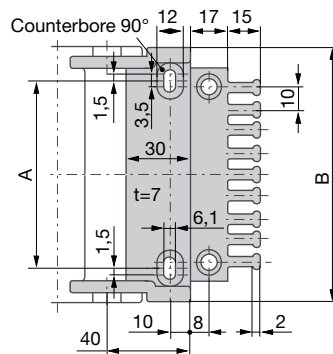

for type 2700.xxx

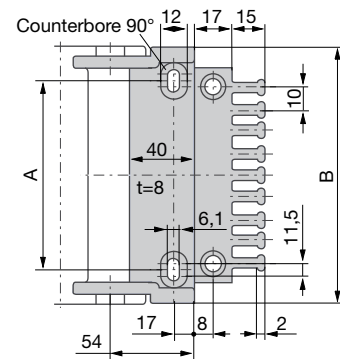

Standard carrier connection

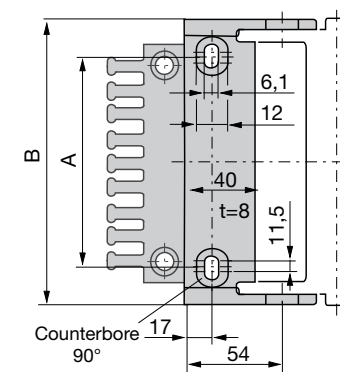
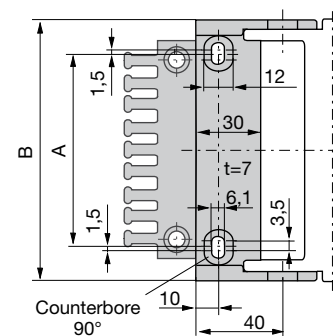
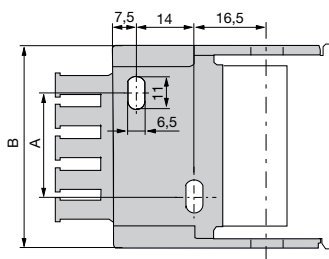

Type	A	B
B15.015..	0	25.5
B15.025..	10	35.5

Type	A	B
2500.03..	25	51
2500.05..	44	70
2500.07..	64	90

Type	A	B
2700.07..	55	93
2700.12..	105	143
2700.17..	155	196

Technical data

for type	Cantilever configuration			Cantilever configuration with permitted sag		
	max. travel [mm]	max. speed [m/s]	max. acceleration ¹ [m/s ²]	max. travel ² [mm]	max. speed [m/s]	max. acceleration [m/s ²]
B15.xx	2000	10	20	2400	3	6
2500.xx	2300	10	20	4000	3	6
2700.xx	3000	10	20	4300	3	6

¹ Higher speeds or accelerations will reduce the lifetime of the cable carrier.
Usual lifetime range with cantilever configuration: 5 - 10 Million strokes.

² For longer strokes, a sliding chain configuration is used. Please contact the supplier.

Guidelines for using cable carriers



Use only electrical cables suitable for use in cable carriers. Hose lines should be highly flexible and should only extend or shorten slightly under pressure. Weight should be distributed across the cable track as evenly as possible! Cables must not be twisted when routed in the cable carrier and should be routed next to one another and as loosely as possible.

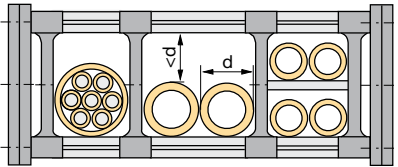

Avoid laying several lines on top of each other and laying lines of different diameters directly next to one another. If multiple layers must be used, separating strips should be inserted between each layer - should such circumstances arise, please contact Parker.

If there is no alternative to routing several lines beside each other without sub-divisions, the clearance height within the carrier must be less than the line diameter. This is the only way of preventing the cables from twisting.

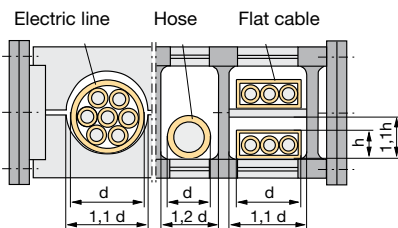

The supply cables must be free to move within the cable carrier. They cannot be fixed to the cable carrier or tied together. **Separating strips** must always be inserted between flat cables routed in multiple layers.

Recommended dimensions of the space required:

- for round cables: approx. 10 % of the line diameter
- with flat cables: for each, approx. 10 % of the cable width and cable thickness
- with hose lines: approx. 20 % of the hose diameter

Thin highflex cables with a low bending strength must be bundled and inserted into a protective hose. The cross section of the protective hose must be much larger than the sum of the individual cable cross sections. For the calculation of the cross section you should assume a standard clearance of 10 % of the individual line diameter.

Load diagrams

Self-supporting length depending on the additional load

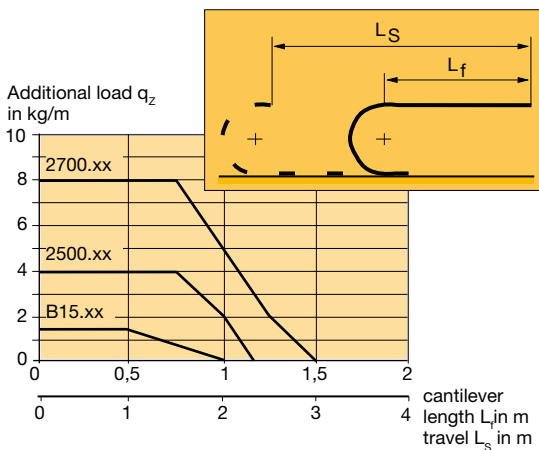

Length with permitted sag LD and travels

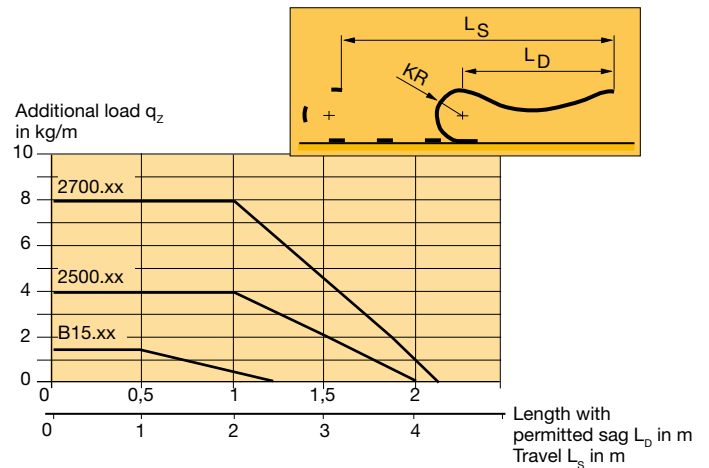

Determination of the chain length

$$L_K = \frac{S}{2} + K$$

Bending radius KR	K					Round LK to pitch t
	38	55	100	150	200	
B15.xx	185	--	--	--	--	30.5
2500.xx	--	276	414	578	--	46
2700.xx	--	--	--	--	825	56

Additional Accessories / Software

Belt tension measuring device RSM:

For accurately setting the toothed belt tension. (Art. No.: 037-000201)



DimAxes:

Dimensioning software for EME linear modules HPLA, HLE, HZR, HTR, BLMA - for PCs as from Windows version 95



Free download of the DimAxes Software or CAD files, catalogs and manuals, partly in different languages on:
<http://www.parker-eme.com/hle>

HLE Order Code

HLE Linear Actuator

	L	E					P													
Drive system																				
Toothed belt drive		B																		
Idler unit		N																		
Frame size																				
100 (Dimensional drawing page 18)			1	0	0															
150 (Dimensional drawing page 20)			1	5	0															
Carriage																				
Standard carriage with load attachment plate							S													
Standard carriage with bar							T													
Extended carriage with load attachment plate							E													
Extended carriage with bar							F													
Special carriage with load attachment plate (on request)							C													
Special carriage with bar (on request)							D													
Extra (e.g. two or more carriages, on request)							X													
Guide system																				
Plastic coated rollers							P													
Stroke																				
State desired stroke [mm]								n	n	n	n	n								
Drive options (see figures below)																				
Shaft on left (Dimensional drawings: see pages 19, 21)													S	L						
Shaft on right (Dimensional drawings: see pages 19, 21)													S	R						
Shaft on both sides (Dimensional drawings: see pages 19, 21)													S	B						
Toothed pulley separately included for bearing directly on the shaft, prepared for drive mounting on the left													N	L						
Toothed pulley separately included for bearing directly on the shaft, prepared for drive mounting on the right													N	R						
Gearbox on the left, additional shaft on the right (Dimensional drawings: see pages 19, 21)													L	R						
Gearbox on the right, additional shaft on the left (Dimensional drawings: see pages 19, 21)													R	L						
Without drive – idler unit (Dimensional drawing: see page 22)													N	N						
Extras (others, e.g. center drive for double axes) (on request)													X	X						
Drive flange suitable for																				
								LEB100	LEB150	Pilot H7	Bolt circle	ØShaft bore H7	Shaft length							
Bayside planetary gearbox PS60							x			50	70	16	40							K
Bayside planetary gearbox PS90							x	x		80	100	22	52							M
Bayside planetary gearbox PS115								x		110	130	32	68							P
Stöber planetary gearbox P3							x			60	75	16	48							A
Flange suitable for Stöber planetary gearbox P4							x	x		70	85	22	56							B
Flange suitable for Stöber planetary gearbox P5							x			90	120	32	88							C
Flange suitable for planetary gearbox PL4-OP11 or PE4							x			80	100	20	40							Q
Flange suitable for planetary gearbox PL5-OP11 or PE5							x	x		110	130	25	55							R
Without gearbox flange (for idler unit NN and drive options SL, SR, SB)																				N
Extra (others, non standard, on request)																				X
Center distance for double axes (from axis center to axis center)																				
Specify required center distance (in mm)														n	n	n	n	n		
State for single axis or idler unit														0	0	0	0	0		
Steel strip cover (see on page 14)																				
Without steel strip cover																				N
With steel strip cover (protection class IP30) (Not for carriage types with bar T, F, D)																				C
Material version																				
Standard versions																				N
Stainless version (V2A)																				V
Linear encoder																				
Without linear encoder (standard)																				N
With linear encoder																				L

Drive Options

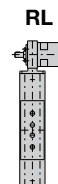
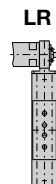
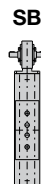
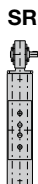

Additional information available on:

www.parker-eme.com/hle



WARNING – USER RESPONSIBILITY

FAILURE OR IMPROPER SELECTION OR IMPROPER USE OF THE PRODUCTS DESCRIBED HEREIN OR RELATED ITEMS CAN CAUSE DEATH, PERSONAL INJURY AND PROPERTY DAMAGE.

- This document and other information from Parker-Hannifin Corporation, its subsidiaries and authorized distributors provide product or system options for further investigation by users having technical expertise.
- The user, through its own analysis and testing, is solely responsible for making the final selection of the system and components and assuring that all performance, endurance, maintenance, safety and warning requirements of the application are met. The user must analyze all aspects of the application, follow applicable industry standards, and follow the information concerning the product in the current product catalog and in any other materials provided from Parker or its subsidiaries or authorized distributors.
- To the extent that Parker or its subsidiaries or authorized distributors provide component or system options based upon data or specifications provided by the user, the user is responsible for determining that such data and specifications are suitable and sufficient for all applications and reasonably foreseeable uses of the components or systems.

Parker Worldwide

AE – UAE, Dubai
Tel: +971 4 8127100
parker.me@parker.com

AR – Argentina, Buenos Aires
Tel: +54 3327 44 4129

AT – Austria, Wiener Neustadt
Tel: +43 (0)2622 23501-0
parker.austria@parker.com

AT – Eastern Europe,
Wiener Neustadt
Tel: +43 (0)2622 23501 900
parker.easteurope@parker.com

AU – Australia, Castle Hill
Tel: +61 (0)2-9634 7777

AZ – Azerbaijan, Baku
Tel: +994 50 2233 458
parker.azerbaijan@parker.com

BE/LU – Belgium, Nivelles
Tel: +32 (0)67 280 900
parker.belgium@parker.com

BR – Brazil, Cachoeirinha RS
Tel: +55 51 3470 9144

BY – Belarus, Minsk
Tel: +375 17 209 9399
parker.belarus@parker.com

CA – Canada, Milton, Ontario
Tel: +1 905 693 3000

CH – Switzerland, Etoy
Tel: +41 (0) 21 821 02 30
parker.switzerland@parker.com

CL – Chile, Santiago
Tel: +56 2 623 1216

CN – China, Shanghai
Tel: +86 21 5031 2525

CZ – Czech Republic, Klecany
Tel: +420 284 083 111
parker.czechrepublic@parker.com

DE – Germany, Kaarst
Tel: +49 (0)2131 4016 0
parker.germany@parker.com

DK – Denmark, Ballerup
Tel: +45 43 56 04 00
parker.denmark@parker.com

ES – Spain, Madrid
Tel: +34 902 33 00 01
parker.spain@parker.com

FI – Finland, Vantaa
Tel: +358 (0)20 753 2500
parker.finland@parker.com

FR – France, Contamine s/Arve
Tel: +33 (0)4 50 25 80 25
parker.france@parker.com

GR – Greece, Athens
Tel: +30 210 933 6450
parker.greece@parker.com

HK – Hong Kong
Tel: +852 2428 8008

HU – Hungary, Budapest
Tel: +36 1 220 4155
parker.hungary@parker.com

IE – Ireland, Dublin
Tel: +353 (0)1 466 6370
parker.ireland@parker.com

IN – India, Mumbai
Tel: +91 22 6513 7081-85

IT – Italy, Corsico (MI)
Tel: +39 02 45 19 21
parker.italy@parker.com

JP – Japan, Tokyo
Tel: +(81) 3 6408 3901

KR – South Korea, Seoul
Tel: +82 2 559 0400

KZ – Kazakhstan, Almaty
Tel: +7 7272 505 800
parker.easteurope@parker.com

LV – Latvia, Riga
Tel: +371 6 745 2601
parker.latvia@parker.com

MX – Mexico, Apodaca
Tel: +52 81 8156 6000

MY – Malaysia, Shah Alam
Tel: +60 3 7849 0800

NL – The Netherlands,
Oldenzaal
Tel: +31 (0)541 585 000
parker.nl@parker.com

NO – Norway, Ski
Tel: +47 64 91 10 00
parker.norway@parker.com

NZ – New Zealand, Mt Wellington
Tel: +64 9 574 1744

PL – Poland, Warsaw
Tel: +48 (0)22 573 24 00
parker.poland@parker.com

PT – Portugal, Leca da Palmeira
Tel: +351 22 999 7360
parker.portugal@parker.com

RO – Romania, Bucharest
Tel: +40 21 252 1382
parker.romania@parker.com

RU – Russia, Moscow
Tel: +7 495 645-2156
parker.russia@parker.com

SE – Sweden, Spånga
Tel: +46 (0)8 59 79 50 00
parker.sweden@parker.com

SG – Singapore
Tel: +65 6887 6300

SK – Slovakia, Banská Bystrica
Tel: +421 484 162 252
parker.slovakia@parker.com

SL – Slovenia, Novo Mesto
Tel: +386 7 337 6650
parker.slovenia@parker.com

TH – Thailand, Bangkok
Tel: +662 717 8140

TR – Turkey, Istanbul
Tel: +90 216 4997081
parker.turkey@parker.com

TW – Taiwan, Taipei
Tel: +886 2 2298 8987

UA – Ukraine, Kiev
Tel: +380 44 494 2731
parker.ukraine@parker.com

UK – United Kingdom,
Warwick
Tel: +44 (0)1926 317 878
parker.uk@parker.com

US – USA, Cleveland
Tel: +1 216 896 3000

VE – Venezuela, Caracas
Tel: +58 212 238 5422

ZA – South Africa,
Kempton Park
Tel: +27 (0)11 961 0700
parker.southafrica@parker.com

European Product Information Centre
Free phone: 00 800 27 27 5374
(from AT, BE, CH, CZ, DE, DK, ES, FI, FR, IE,
IT, NL, NO, PL, PT, RU, SE, UK, ZA)

Ed. 2009-03-11

We reserve the right to make technical changes. The data correspond to the technical state at the time of printing.
© 2010 Parker Hannifin Corporation

192-510011N12

February 2010



Parker Hannifin GmbH
Electromechanical Automation
Robert-Bosch-Straße 22
D-77656 Offenburg, Germany
☎ +49 (0)781 / 509-0
📠 +49 (0)781 / 509-98176
sales.automation@parker.com
www.parker-eme.com

Parker Hannifin GmbH
Vertriebs- und Servicezentrale
Pat-Parker-Platz 1
D-41564 Kaarst
☎ +49 (0)2131 / 4016-0
📠 +49 (0)2131 / 4016-9199
parker.germany@parker.com
www.parker.com